

Cassava in Tropical Africa

A Reference Manual



unicef

United Nations Children's Fund

CASSAVA IN TROPICAL AFRICA

A Reference Manual

INTERNATIONAL INSTITUTE OF TROPICAL AGRICULTURE
Ibadan, Nigeria

© 1990

International Institute of Tropical Agriculture

Oyo Road, PMB 5320
Ibadan, Nigeria

Telex: 31159 or 31417 TROPIC NG

Cable: TROPFOUND IKEJA

Telephone: (234-22) 400300-400318

ISBN 978 131 041 3

Edited and designed by Chayce Publication Services, United Kingdom

Printed and bound in the United Kingdom by Balding + Mansell International, Wisbech

Contents

Introduction	vii
Part I Production Constraints	
<i>Unit 1</i> Production constraints	1
Part II Strategies for Overcoming Constraints	
<i>Unit 2</i> Morphology and physiology	11
<i>Unit 3</i> Breeding	21
<i>Unit 4</i> Rapid multiplication	29
<i>Unit 5</i> Tissue culture	41
<i>Unit 6</i> Agronomy	53
<i>Unit 7</i> Crop protection	69
Part III Postharvest Technology	
<i>Unit 8</i> Storage of fresh cassava	83
<i>Unit 9</i> Cassava processing	87
<i>Unit 10</i> Utilization of cassava and its products	113
Part IV Research	
<i>Unit 11</i> Data collection and organization	121
<i>Unit 12</i> On-farm research	139
Glossary	169
Recommended reading	173

List of Figures and Tables

Unit 1 Production constraints

- Figure 1.1* Cassava leaf showing symptoms of African cassava mosaic virus
- Figure 1.2* Cassava stem showing bacterial gum exudations resulting from CBB infection
- Figure 1.3* Cassava leaf showing an attack of CBB
- Figure 1.4* Cassava plant showing defoliated stems, commonly referred to as 'candlesticks', resulting from severe CBB infection
- Figure 1.5* Cassava leaf showing an attack of brown leaf spot
- Figure 1.6* Infected cassava tuber showing white mycelial growth
- Figure 1.7* Mealybug infestation of cassava leaves
- Figure 1.8* Cassava plant showing attack by elegant grasshopper
- Figure 1.9* Cassava stem stripped down to the pith following grasshopper attack

Unit 2 Morphology and physiology

- Figure 2.1* General morphology of the cassava plant
- Figure 2.2* Transverse section of young tuber
- Figure 2.3* Inflorescence of a cassava plant
- Figure 2.4* Fruit and seed of a cassava plant
- Figure 2.5* Growth and development in cassava

Unit 3 Breeding

- Figure 3.1* Pollination by hand
- Figure 3.2* Bagged pollinated flowers
- Figure 3.3* Seedlings growing in a nursery
- Figure 3.4* IITA cassava breeding scheme

Unit 4 Rapid multiplication

- Figure 4.1* Ministem cuttings: tip shoot (left), semi-mature (center) and hardwood (right)
- Figure 4.2* Examples of tools used to prepare ministem cuttings: shears (left), secateurs (center) and a hand saw (right)
- Figure 4.3* Semi-mature ministem cuttings planted in a nursery bed

- Figure 4.4* Hardwood ministem cuttings showing root and shoot growth (planted horizontally)
- Figure 4.5* Semi-mature ministem cuttings showing root and shoot growth (planted vertically)
- Figure 4.6* Semi-matured ministem cuttings growing in polyethylene bags
- Figure 4.7* Semi-mature ministem cuttings growing in the nursery
- Figure 4.8* Cassava stems stored upright
- Figure 4.9* Cassava stems stored on a horizontal support system

- Table 4.1* Percentage of field establishment for cassava ministem cuttings pre-sprouted in perforated polyethylene bags

Unit 5 Tissue culture

- Figure 5.1* Process of meristem culture and plantlet development
- Figure 5.2* Rapid multiplication of disease-free cassava for distribution
- Figure 5.3* A humidity chamber
- Figure 5.4* Removing the plantlet from the tube
- Figure 5.5* Handling the plantlet

Unit 6 Agronomy

- Figure 6.1* Cassava growing on mounds
- Figure 6.2* Cassava growing on ridges
- Figure 6.3* Cassava growing on the flat
- Table 6.1* Nutrients removed by cassava grown on different types of soil in Madagascar
- Table 6.2* Equivalent amounts of nutrients (kg/ha) removed by cassava cultivars and yam species through crop harvest in Nigeria, expressed as fertilizers
- Table 6.3* Effect of time of harvest on yield of different varieties (kg/plot)
- Table 6.4* Effect of time of harvest on the percentage of starch
- Table 6.5* Main characteristics of some improved IITA cassava varieties

Unit 7 Crop protection

Figure 7.1 Cassava plant damaged by cassava mealybug

Figure 7.2 Cassava plant damaged by cassava green mite

Figure 7.3 Stages in a biological control program

Unit 8 Storage of fresh cassava

Figure 8.1 Fully filled trenches under a shed

Figure 8.2 Cassava tubers stored in a trench

Figure 8.3 Three types of containers used for storing cassava tubers in sawdust

Unit 9 Cassava processing

Figure 9.1 Steeping cassava tubers for the preparation of lafun

Figure 9.2 Drying manually pulverized cassava on rocks

Figure 9.3 Peeling cassava manually

Figure 9.4 Grating the tubers manually

Figure 9.5 Dehydrating and fermenting cassava mash

Figure 9.6 Sieving cassava mash

Figure 9.7 Frying gari

Figure 9.8 Gari being sold

Figure 9.9 Flow chart of gari manufacture

Figure 9.10 Washing and grating cassava tubers

Figure 9.11 Power screw dehydrating press

Figure 9.12 Mechanical sifter for mash and gari

Figure 9.13 Frying gari (improved)

Figure 9.14 Flow chart for preparation of chips and flour from low-cyanide cassava varieties

Figure 9.15 Flow chart for preparation of detoxified flour from high-cyanide cassava varieties

Figure 9.16 Flow chart for manufacture of starch

Figure 9.17 Layout of cassava-processing industry

Figure 9.18 A typical cassava grater

Figure 9.19 Hydraulic jack press

Figure 9.20 RAIDS gari fryer

Figure 9.21 Manually operated slicing machines

Figure 9.22 Multipurpose bin dryer

Figure 9.23 Cabinet dryer, showing cross-section

Figure 9.24 Hammer mill

Figure 9.25 Brook dryer, showing cross-section

Table 9.1 Machinery and implements for cassava-processing industries

Unit 10 Utilization of cassava and its products

Figure 10.1 Bread with 20% cassava flour made from IITA improved varieties

Table 10.1 Composition of cassava products prepared traditionally in Cameroon

Table 10.2 Composition of cassava leaves and selected other food items in terms of per 100g edible portion, fresh weight

Table 10.3 Animal feed rations using cassava meal

Unit 11 Data collection and organization

Figure 11.1 Record sheet used in a cassava breeding program

Table 11.1 Analysis of variance table for Completely Randomized Design

Table 11.2 Analysis of variance table for Randomized Complete Block Design

Table 11.3 Two-way table of blocks x treatments

Table 11.4 Complete analysis of variance table

Table 11.5 Comparison of treatment means and LSD

Unit 12 On-farm research

Figure 12.1 Flow chart of OFR activities and their inter-relationships

Figure 12.2 Target areas with their representative pilot research area

Figure 12.3 Rainfall and evapotranspiration at Ibadan, Nigeria, 1953-1973

Figure 12.4 Cassava-based systems and associated mean rainfall distribution in the Ohsu area

Figure 12.5 Calendar of farm operations indicating peak periods in the Ohsu area

Figure 12.6 IITA cassava-based system survey, Ohsu

Figure 12.7 IITA cassava-based system survey, Ohsu

Figure 12.8 On-station research

Table 12.1 Suggested contents of the report on the pilot research area

Table 12.2 Checklist of information to be collected during the field survey

Table 12.3 Treatment combinations in an on-farm trial with improved cassava and soybean

Table 12.4 Costs and returns for cassava/soybean system in the Ohsu area

INTRODUCTION

CASSAVA IS ONE OF the most important food crops in Africa. It derives its importance from the fact that its starchy, thickened, tuberous roots are a valuable source of cheap calories, especially in developing countries where calorie deficiency and malnutrition are widespread. In many parts of Africa, the leaves and tender shoots of cassava are also consumed as vegetables.

Over two-thirds of the total production of cassava is consumed in various forms by humans. Its usage as a source of ethanol for fuel, energy in animal feed, and starch for industry is increasing. The crop is amenable to agronomic as well as genetic improvement, has a high yield potential under good conditions and performs better than other crops under sub-optimal conditions. It is grown widely in several countries in sub-Saharan Africa and Madagascar. It was introduced into Africa in the latter half of the 16th century from South America and perhaps also from Central America, where it is believed to have originated.

The importance of cassava in food security and nutrition issues has led IITA and the United Nations Children's Fund (UNICEF) to establish their joint Household Food Security and Nutrition Program, with the goal of extending the benefits of IITA research to African countries through UNICEF's country programs of social mobilization and development. The collaboration has consisted chiefly of compiling baseline information; distributing improved planting materials; and training trainers in improved production, storage, processing and utilization technologies. UNICEF has, among other forms of support, contributed funds toward the costs of publication and translation of the present manual on cassava production and utilization in tropical Africa.

This manual is designed to be both a teaching aid for cassava training sessions and a convenient reference for those involved in the production and postharvest technology of the crop. It is divided into four parts, and together these parts contain 12 units.

Part I deals with production constraints. It consists of one unit which covers the main factors accounting for low yields and the problems associated with postharvest technology: diseases and pests; weeds; soils and agronomic factors; and socioeconomic factors.

Part II deals with the strategies for overcoming production constraints encountered in cassava cultivation. There are six units. The morphology and physiology unit discusses the biology of the cassava plant and suggests possible strategies to increase tuber yield based on a better understanding of the crop. The unit on breeding reviews the efforts aimed at incorporating into cassava varieties all the desirable characteristics associated with high and stable yields, expressed in terms of both quantity and quality. This is followed by the unit on rapid multiplication. Tissue culture approaches to multiplying and distributing plants which are resistant to virus infections are discussed in the unit on tissue culture. The unit on agronomy discusses the production aspects in terms of soils and agronomic practices. The final unit in Part II discusses crop protection in terms of disease and pest control.

Part III deals with postharvest technology, which encompasses storage, processing and utilization. Cassava is a highly perishable crop, and the problems of postharvest losses are well known. The unit on storage discusses traditional and improved methods of cassava storage. In the unit on processing, traditional and

improved methods of cassava processing are described, with emphasis on some of the major products, such as gari, flour and starch. The unit on utilization deals with the use of cassava and processed cassava products in human and animal nutrition and in industry.

Part IV deals with research and comprises two units. The unit on data collection and organization covers commonly used research designs and the collection, analysis and interpretation of data; standard scoring systems for the diseases, pests and agronomic characteristics of cassava are also discussed. The final unit in this manual deals with on-farm research and on-farm experimentation with cassava. The first part of the unit discusses the concept of the farm as a system and the on-farm research process; the second part presents an example of on-farm experimentation, including researcher-managed and farmer-managed trials.

Part I

Production constraints



UNIT 1

Production Constraints

The constraints on cassava production in Africa include diseases, pests, weeds, soil and agronomic factors, and socioeconomic factors. These constraints have contributed to keeping the average cassava yield in Africa at 6.4 tons/ha, which is well below the world average of 8.8 tons/ha. Efforts to increase production must be based on an understanding of the constraints in order to eliminate or contain them.

Diseases

The major diseases of cassava are leaf diseases, stem diseases and tuber rot.

Leaf diseases

African cassava mosaic virus (ACMV). First reported in East Africa in 1894, cassava mosaic is the most widespread disease of cassava in tropical Africa and India. Although it was postulated in 1906 that the causal organism was a virus, it was not until 1983 that the etiology of cassava mosaic was confirmed beyond doubt.

The causal organism, ACMV, is a geminivirus (paired or bonded virus particles) averaging 20 x 30 nanometers. It is transmitted from one cassava plant to another by the whitefly, *Bemisia tabaci*. It is also spread between plantations and from one region to another by the use of infected planting materials. Symptoms of cassava mosaic disease include characteristic light green, yellow or white patches, irregularly intermingled. The chlorotic areas may be only small flecks or spots, or they may cover the entire cassava leaf (see Figure 1.1). The mottling is sometimes accompanied by leaf deformation and a general stunting of the plant. On cassava plants which are stunted, the diseased leaves are small, with



Figure 1.1
Cassava leaf showing symptoms of African cassava mosaic virus



Figure 1.2
Cassava stem showing bacterial gum exudations resulting from CBB infection



Figure 1.3
Cassava leaf showing an attack of CBB



Figure 1.4
Cassava plant showing defoliated stems, commonly referred to as 'candlesticks', resulting from severe CBB infection

asymmetrical development of the entire lobes. Yield losses may range from 20 to 60%.

Cassava bacterial blight disease (CBB). This is the most widespread bacterial disease of cassava and is second in importance only to ACMV in Africa. It was first reported in Brazil in 1912 and now occurs in all cassava-growing areas of the world. In Africa, it was first reported in Madagascar in 1946.

The causal organism is a bacterium, *Xanthomonas campestris pathovar manihotis*. The symptoms include characteristic angular water-soaked leaf spot, blight, gum exudation (see Figure 1.2), stem die-back, wilt (see Figure 1.3) and vascular necrosis. Severe attack results in rapid defoliation of the plant, leaving bare stems commonly referred to as 'candlesticks' (see Figure 1.4). Yield loss varies from 20 to 100%, depending upon the cultivar, bacterial strain and environmental conditions.

Cassava angular leaf spot. This disease is caused by the bacterium *Xanthomonas campestris pathovar cassavae*. It is not as widespread as CBB, being restricted to Uganda, Kenya, Tanzania, Rwanda, eastern Zaïre and Malawi.

The symptoms are similar to those caused by CBB but the disease is not systemic. The leaf spots are usually surrounded by a chlorotic halo. Although infected plants are defoliated, they never 'die back'. Yield losses attributable to cassava angular leaf spot have not been quantified.

Cercospora leaf spot. There are three types of cercospora leaf spot. The most common one is brown leaf spot, caused by *Cercosporidium henningsii* (see Figure 1.5). The other types are leaf blight, caused by *Cercospora vicosae*, and white leaf spot, caused by *Cercospora caribae*.

Although severe attacks by these micro-organisms have been reported in several African countries, they are not known to kill plants. The symptoms are restricted to older leaves and set in after tuberization has occurred. Yield losses are minor for white leaf spot and leaf blight but may reach about 20% for brown leaf spot.



Figure 1.5
Cassava leaf showing an attack of brown leaf spot

Stem diseases

Cassava anthracnose disease (CAD). Caused by *Colletotrichum gloeosporioides* f. sp. *manihotis*, CAD is the most important stem disease in Africa; it occurs in all major cassava-growing areas. A sap-sucking coreid bug, *Pseudotheraptus devastans*, is reported to be partly responsible for the spread of the disease.

The fungus attacks mainly the stem, twigs and fruits, causing deep wounds ('cankers'), leaf spotting and tip die-back. The first symptoms appear on the young stems as slightly depressed oval lesions which quickly turn dark brown. On the older stems, raised fibrous lesions eventually develop into deep cankers which make the stems brittle. The incidence and severity of the disease have not been correlated with yield loss in the field but the infected stems produce poor quality planting material; this material does not



Figure 1.6
Infected cassava tuber showing white mycelial growth

establish well in the following planting season and thus yields are reduced.

Tuber rot

Some soil-borne pathogens attack cassava roots, which causes damping-off disease at the early stages of growth or soft rot or dry rot in tubers prior to harvest.

Sclerotium rot. Caused by a fungus, *Sclerotium rolfsii*, this is the most common tuber rot disease and occurs on roots and tubers at all stages of development. It can be recognized by the appearance of a white mycelial growth on infected roots and tubers (see Figure 1.6). As the fungus penetrates the tubers, the plants begin to show mild wilting symptoms.

Soft rot. These diseases are caused by *Phytophthora drechsleri*, *Pythium* spp., and *Fusarium solani*, and occur under wet conditions and cooler temperatures. The causal organisms attack and kill small feeder roots and cause necrotic brown lesions on older roots. As the roots decay, they infect the tubers which then emit pungent odors. Unharvested tubers become more susceptible to this type of rot. When roots and tubers rot, the entire plant wilts, defoliates and dies. In the cool, wet conditions that favor the development of these diseases, losses may be as high as 80%.

Dry rot. Several fungi cause dry rot, including *Fomes* (*Rigidiporus*) *lignosus*, *Armillariella mellea*, *Rosellinia necatrix* and *Botryodiplodia theobromae*. The disease usually occurs on land that has recently been cleared of trees and shrubs. Infected tubers are typically covered with rhizomorphs (thread-like network of mycelia) of the fungus. The plant wilts, but does not shed its leaves; eventually, the entire plant dehydrates, turns brown and appears scorched.

Pests

Vertebrate pests

There are two major vertebrate pests of cassava: the African bushfowl, *Francolinus bicalcaratus bicalcaratus*, and the cane rat, *Thryonomys swinderianus*.

Bushfowl become pests only after the tubers have been formed and after grain crops have been harvested. They peck at the soil

with their beak until contact is made with the tubers, upon which they feed. Tubers damaged in this way are easily invaded by rot-causing micro-organisms, leading to their total loss. In highly infested areas, tuber loss resulting from bushfowl damage may be as high as 30%.

Cane rats eat cassava stems and tubers. They dig at the tubers, and the wounds made on large tubers during feeding become sources of infection for the smaller tubers. On unprotected farms, yield losses can be as high as 40%.

Nematodes

At least 45 genera and species of nematodes are known to be associated with cassava. They infect the roots and render them more susceptible to rot-causing organisms. The root knot nematode, *Meloidogyne incognita*, is a particularly serious problem in Africa's cassava-growing areas. Other *Meloidogyne* species reported on cassava include *M. javanica*, *M. hapla* and *M. arenaria*. Root tips of infected plants are devitalized and their growth halted.

The lesion nematode, *Pratylenchus brachyurus*, the spiral nematode, *Helicotylenchus erythrinae*, and the reniform nematode, *Rotylenchulus reniformis*, are also found on cassava. An attack by these pests causes the plant to lose vigor, and the resulting yield losses range between 17 and 50%.

Mites

The most important cassava pests in Africa are cassava green spider mite (CGM) and red spider mite (RSM). Indigenous to South America, CGM was first reported in Uganda in 1972. It has since spread rapidly over much of Africa. Only one species is found on the continent, *Mononychellus tançioa*.

CGM sucks cells from leaf tissue. The damage first appears on the surface of developing and newly formed leaves. Symptoms vary from a few chlorotic spots to complete chlorosis and may be mistaken for ACMV symptoms. Heavily attacked leaves are stunted and deformed. Mite incidence is high in the dry season and leads to a 20-80% tuber yield loss, depending on severity of the attack.

There are four species of RSM in Africa: *Oligonychus gossypii*, *Tetranychus telarius*, *T. neocaledonicus* and *T. cinnabarinus*. The pest is visible to the naked eye as a red speck with four pairs

of legs. Symptoms of attack appear on the upper surface of fully mature leaves as chlorotic pin pricks along the main vein; these pin pricks may increase to cover the whole leaf, turning the surface reddish-brown. A protective web is usually seen on the leaf. Under severe attack, the leaves may die and be shed. Infestation starts in the dry season, and it is during this season that most damage is done.

Insects

There are at least six major insect pests of cassava in Africa: the cassava mealybug, *Phenacoccus manihoti*; the variegated grasshopper, *Zonocerus variegatus*; the elegant grasshopper, *Z. elegans*; the cassava scale insect, *Aonidomytilus albus*; the coreid bug, *Pseudotheraptus devastans*; and the whitefly, *Bemisia tabaci*. Other pests include the striped mealybug, *Ferrisia virgata*, and the green mealybug, *Phenacoccus madeirensis*.

Cassava mealybug (CM). This is a very serious pest in Africa. It is indigenous to South America but was accidentally introduced into Africa in the early 1970s through vegetative planting material. First reported in Zaïre in 1973, it has spread to almost all cassava-growing areas in Africa.



Figure 1.7
Mealybug infestation of cassava leaves

The mealybug sucks sap from the phloem. Initially, it attacks the terminal ends of cassava shoots; later, it spreads to the petiole and expanded leaves (see Figure 1.7). The shoot stunting and the

resultant shortening of the internodes are believed to be caused by a toxigenic substance present in the insect's saliva. In cases of severe infestation, green shoots die but die-back may not occur. A distinct dry season is required for a build-up of the mealybug population; drought stress and high temperatures (28°C is optimal) favor pest incidence. Tuber loss resulting from mealybug infestation has been estimated to range from 70 to 80%.

Variegated and elegant grasshoppers. The variegated grasshopper occurs in West and East Africa. The elegant grasshopper is found mainly in southern Africa, as far north as Angola and Mozambique.

Both species are serious cassava pests. They feed on the leaves (see Figure 1.8), petioles and green shoots, and strip the stem down to the pith (see Figure 1.9). They are particularly devastating when the dry season is prolonged. Yield loss resulting from defoliation and bark feeding can range from 20 to 60%, especially if the crop is infested in the first 7 months of growth.

Cassava scale insect. Found in West and East Africa, these insects cover first the lower stem (older part) of cassava plants and then the leaves and petioles. They occasionally kill the host plant if it has already been weakened by other pests and drought.

Coreid bug. These sap-sucking bugs are believed to be partly responsible for the spread of CAD in Zaïre and the Congo. They carry enough inoculum, either internally or in a crude mechanical way, to cause CAD, and the disease is known to develop from their feeding points on the plant.

Whitefly. This insect is the vector of ACMV, and is prevalent throughout Africa. The reproduction and activity of the whitefly are encouraged by high rainfall, a temperature range of 25 to 27°C and high light intensity. Under field conditions, the spread of ACMV by whitefly occurs mainly in April, May and June when the population is high.

Weeds

Cassava can be seriously affected by early weed infestation. Slow initial growth and development make the plant susceptible to weed interference during the first 3 to 4 months after planting.

Weed competition in cassava crops reduces canopy development, tuberization and tuber number. Reduction in tuber yields



Figure 1.8
Cassava plant showing attack by elegant grasshopper



Figure 1.9
Cassava stem stripped down to the pith following grasshopper attack

varies from 40% in the early-branching cultivars to nearly 70% in the late- or non-branching cultivars. Depending on previous use of the land, soil fertility status and cultivar, yield losses caused by uncontrolled weed growth in cassava can reach 100%.

At least two properly timed hand weedings are needed when the plant population exceeds 10 000 stands/ha; this is particularly important in the case of early-branching cultivars that branch at heights of less than 1m. However, most farmers grow cassava at a lower plant population, which does not provide effective ground cover; under these conditions three or four weedings are necessary for good crop yields.

Failure to plant cassava at the recommended plant population and to carry out the first weeding in time contributes to low yields, even when improved varieties are used. Delaying the first weeding by more than 2 months can cause over 20% reduction in tuber yield, even if the crop is subsequently weeded three times. Cassava production in areas infested with the weed *Imperata cylindrica* requires four or five weedings to minimize weed-related yield losses.

Improved early-branching cassava cultivars are able to develop canopy to shade out weeds if:

- early growth is vigorous
- the crop is kept free from weed competition during the first 3 to 4 months after planting
- the crop is planted at a plant population of not less than 10 000 stands/ha
- pests are not a major problem
- environmental conditions and soil fertility status are favorable to cassava growth and development

Among the major weeds associated with cassava production are grasses such as *Andropogon* spp., *Imperata cylindrica*, *Panicum maximum* and *Pennisetum* spp., and broadleaved weeds such as *Commelina* spp., *Chromolaena odorata*, *Mimosa invisa*, *Smilax kraussiana* and *Mucuna puriens*. The problem with *I. cylindrica* is not limited to direct yield reduction; this weed also causes mechanical damage to cassava tubers which provides a route of entry for fungi and other pathogens that cause tuber rot and reduce quality of produce.

Soil and agronomic factors

The important soil and agronomic factors that affect cassava production are soil temperature and moisture, soil erosion and low soil fertility, and poor cultural practices.

Although cassava has a slightly higher optimum range of soil temperature regime than maize or soybean, supra-optimal soil temperature (above 30°C) can cause significant growth reduction. There are also significant yield reductions if drought is frequent and if the crop is grown on soils with a low water-holding capacity. Some cassava cultivars tend to promote soil erosion because of a slow rate of canopy development. Continuous cultivation of cassava, without adequate erosion control measures, can result in severe and irreversible soil degradation.

In traditional systems, land preparation starts before the onset of the rainy season and consists of clearing the vegetation and burning it. Mounds or ridges are made at the beginning of the rains. On sandy soils there is little land preparation; farmers merely slash weeds and plant cassava cuttings in relatively undisturbed soil.

Traditional farmers seldom follow recommended cultural practices for cassava, and may be unaware of the existence of improved varieties. The use of unimproved varieties, together with inadequate length and age of planting material and incorrect plant population, depth and time of planting, are among the reasons why yields under most traditional systems are low. The selection of good planting material is one of the most important aspects of cassava production; the material must be fresh and taken from healthy and mature stem portions if high yields are to be realized.

Socioeconomic factors

The main socioeconomic factors affecting cassava production relate to inadequate resource allocation, infrastructure and extension services.

Resource allocation

The shortage of labor, land and capital are important resource constraints for cassava production. Recent trends indicate a decline in the rural farm population, with the result that farm labor is scarce and expensive during critical periods, particularly at planting and weeding times. Among the reasons for labor short-

ages are that young adults are migrating to the cities, children are at school during periods of peak labor demand, and there are fewer active farmers among the ageing population in the rural areas.

In several cassava-growing areas, there are no effective land use policies and farm holdings are small. Because of population pressures, fallow periods have been shortened, leading to more intensive cultivation of marginal lands; also, cassava is seen as a low nutrient-requirement crop and thus is usually the last crop in the rotation, resulting in low yields.

Lack of capital means that farmers cannot afford to hire labor. There is no institutionalized farm credit system to assist small farmers (the majority of cassava producers in Africa). This has resulted in limited farm sizes and investment in cassava production and processing. The need to develop improved storage and processing facilities is particularly important for cassava as it is highly perishable and requires processing before consumption.

Infrastructure

The necessary infrastructure, such as adequate water supplies and transport and marketing systems, is generally lacking in cassava-growing areas, giving producers and processors little incentive to expand operations. An inefficient, expensive transport system adversely affects input/output cost and supply, reducing farmers' potential income from marketing their products. Efficient marketing is needed to get the products to the consumer at the right place and time, in the required form, and at affordable prices.

Extension and input delivery systems

To diffuse new technology on cassava production, processing and utilization among rural farmers, it is necessary to have an efficient extension system. Many farmers are not aware of the availability of improved technologies developed by national programs in collaboration with international research centers, such as IITA. Lack of information poses a 'demand side' constraint that can be overcome if informal educational programs for farmers are provided.

There are also situations where there are 'supply side' constraints. For example, farmers are aware of the existence of inputs, such as insecticides or improved cassava planting materials, but have no access to these inputs. Efforts must be made to ensure that inputs are available at the right time and in the right place.

Part II

Strategies for overcoming constraints



UNIT 2

Morphology and Physiology

Botanically, cassava is a perennial crop, although farmers usually harvest it during the first or second year. It is propagated mainly from stem cuttings; however, under natural conditions, as well as in the plant breeding process, propagation by seed is quite common.

When cuttings are planted in moist soil under favorable conditions, they produce sprouts and adventitious roots within a week. If propagated by seed, plant establishment is considerably slower, the plant itself is smaller and weaker than that produced from a stem cutting and seedlings genetically segregate into different types.

During the few weeks of growth after emergence or sprouting, the shoot lengthens and the roots extend downwards and spread. Flowering may begin as early as the sixth week after planting, although the exact time of flowering depends upon the cultivar and the environment. Tuber formation begins in about the eighth week after planting. Leaf area approaches its maximum size in 4 to 5 months, depending on planting time. The average height of a cassava plant ranges from 1 to 2m, although some cultivars may reach 4m.

Classification of cassava varieties

There are many cultivars or varieties under cultivation. They can be distinguished by such morphological characteristics as leaf size, color and shape, branching habit, plant height, color of stem and petiole, tuber shape and color, time-to-maturity and yield.

Cassava varieties are often classified according to the levels of cyanogenic glucosides (hydrocyanic acid, HCN) in the tuber and leaves. The major groups are:

- cassava with high HCN level — 10mg per 100gm fresh weight or more; an example of this group among the IITA cultivars is TMS 50395
- cassava with low HCN level — less than 5mg per 100gm fresh weight; the HCN is often concentrated in the peel; good examples of low HCN cassava among the IITA cultivars are TMS 30001 and TMS 4(2)1425
- intermediate types, in which the levels of HCN range between 5 and 10mg per 100gm fresh weight; examples among the IITA cultivars include TMS 30572 and TMS 30555

Root and shoot system

The cassava plant may be divided into two main parts, as shown in Figure 2.1:

- the shoot system, which consists of stem, leaves and reproductive structures or flowers
- the root system, which consists of feeder roots and tubers

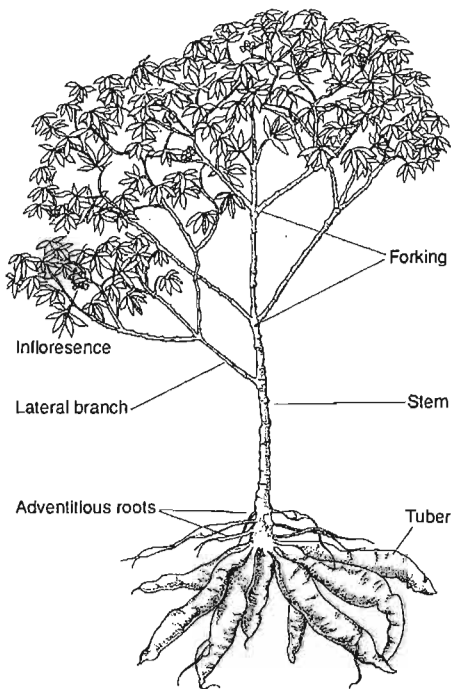

Figure 2.1
General morphology of the cassava plant

Root system

The cassava plant is established from hardwood cuttings. During the first 2 to 3 weeks of growth, adventitious roots develop at the base of the cuttings. These adventitious roots subsequently develop into fibrous root systems which absorb water and nutrients from the soil. Some adventitious roots also develop at the base of the axillary buds on the cuttings, or at the nodes; these are known as 'nodal roots'.

Depending upon variety and age of the plant, fibrous roots may be up to 100cm long. After 30 to 60 days, the roots begin to swell, marking the beginning of tuber initiation. The process of tuberization involves the onset of secondary thickening in fibrous roots; that is, fibrous roots swell as a result of cambium activity. The development of the tuber consists mainly of an increase in the diameter of a root.

The actual number of roots which eventually form tubers depends on several factors, including genotype, assimilate supply, photo-period and temperature.

Genotype. The number of tubers which are produced varies from one variety to another. In general, 4 to 8 tubers per plant may be produced.

Assimilate supply. Generally, the process of cassava tuberization is affected by assimilate supply (that is, the level of photosynthate which is available during tuber initiation). The initiation of tuberization requires a critical percentage of assimilate supply. Therefore, any factor which affects assimilate supply will also affect the number of tubers which are produced. Some examples of these factors are moisture stress, soil fertility status, soil aeration, soil temperatures and radiation.

Photoperiod and temperature. Most varieties initiate tubers only under short-day conditions. Long days delay tuber initiation and thus fewer tubers are produced. Long days also tend to encourage abundant shoot growth. Photoperiods may affect the hormonal balance in the plant; for example, they may influence the level of Gibberellic Acid (GA) and Indole Acetic Acid. Usually, photoperiod interacts with temperature, especially night temperature, but varietal differences in the nature of the interaction are also found.

The cassava tuber is physiologically inactive and cannot therefore be used as planting material. Cassava established from seed first develops a tap root system: the radicle grows vertically downward and develops into a tap root. Later, adventitious/fibrous roots develop from the upper portion of the tap root.

The cross-section of a young tuber (as illustrated in Figure 2.2) shows the following dominant features:

- the periderm, which consists of a few layers of mainly dead cells that effectively seal off the surface of the tuber; the periderm varies in color and may be thick and rough, or thin and smooth
- the cortex, which is the layer of cells (usually white) just below the periderm; the peel of a cassava tuber consists mainly of the cortex and the outer periderm
- the flesh, which is the central portion and consists largely of storage parenchyma cells; this is the main storage region of the plant, where starch grains are deposited; a few xylem elements and laticifers occur at random in the starchy flesh
- the central vascular strands, which consist of xylem bundles and fibers

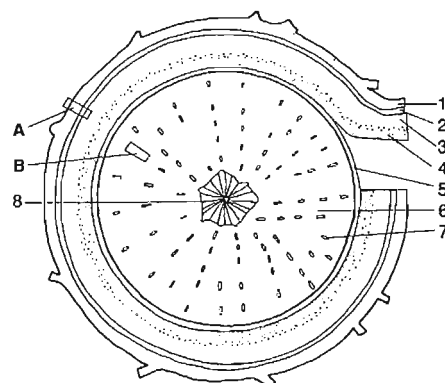

- | | |
|-----------------------|----------------------------|
| 1 Periderm | 5 Cambium |
| 2 Sclerenchyma | 6 Storage parenchyma |
| 3 Cortical parenchyma | 7 Xylem vessel |
| 4 Phloem | 8 Xylem vessels and fibres |
- (1—4 = peel)

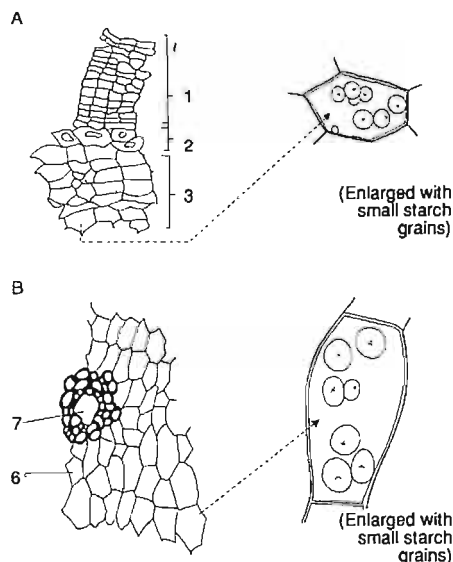

Figure 2.2
Transverse section of a young tuber

Shoot system

The shoot system develops from axillary buds located on the nodes on the cuttings. The number of shoots that develop depends on several factors, which may include:

- length of cuttings and number of nodes (longer cuttings produce more shoots, and cutting orientation affects the number and sites of shoots; cuttings planted in a vertical or inclined position develop shoots mainly at the basal nodes; those planted horizontally may develop shoots at nearly all nodes, though often the middle nodes may not develop any shoots)
- size and moisture content of the cutting (large, fresh cuttings develop relatively more shoots)
- genotype (some cultivars produce more shoots than others)

Cassava stems grow up to 4m tall, but dwarf varieties may be only 1m tall. The stems vary considerably in color (whitish, brown or dark brown), and are usually woody with very large pith. The older parts of stems consist of prominent knob-like scars which are the nodal positions where leaves were originally attached. Each nodal unit consists of a node, which subtends a leaf and an internode. The rate of node production on each stem is about one node per day during early and active growth stages, and about one node per week in older plants.

The internodes vary considerably, depending on varieties and environmental conditions. They tend to be long under favorable conditions, and short under drought stress; where there is insufficient light, they are usually abnormally long.

Branching. There are two types of branching pattern in most varieties growing under normal conditions:

- forking, in which the main stem grows for a while before producing (usually) three branches at the apex of the stem; after a certain growth period, each branch then produces another set of three branches; forking occurs at the apex of the stem when the apical meristem changes to the reproductive state, and it is often associated with flowering
- lateral branching, in which branching occurs on any part of the main stem at some distance from the apex; branches usually arise from one or more leaf axils around the lower portion of the stem

Branching is influenced by several factors, including genotype and physical damage.

Genotype. The number of nodes which occur before the first forking is a function of the variety or genotype. Some clones or varieties fork very early, and thus the branches lie close to the ground; although this makes weeding difficult, it does reduce weed growth. Some cultivars begin to produce branches at a reasonable distance above the ground (1m or more); the advantage here is that the ground beneath the canopy is relatively open and may be intercropped with a low-growing crop. Where cassava is not intercropped, however, weed growth may be a problem.

Even within the same variety, the branching pattern may vary according to environmental conditions. For example, intercropping with a more competitive species may alter the branching pattern considerably; and where there is competition among crops for light, branching may occur at a higher level than in a pure stand. Time of planting also affects the branching height.

Soil fertility. The height at which forking occurs may be determined by soil fertility. Low soil fertility delays forking, with the result that branches usually form at higher stem positions. Some genotypes may not produce branches at all where soils are poor.

Other factors. Water stress and cool temperatures during the growth cycle may delay the formation of branches. The level of available photosynthate may be a major factor in the formation of lateral branches; excess photosynthate, for example, may result in more lateral branches being formed.

Leaves. Cassava leaves are arranged spirally on the stem (in technical terms, the phyllotaxis is a two-fifths spiral). Each leaf is subtended by three to five stipules, each about 1cm long. The length of the leaf stalk (petiole) varies between 5 and 30cm long. The lamina is simple with a smooth margin but deeply palmate or lobed. The number of laminalobes varies between three and nine (usually odd numbers).

Flowering. Cassava is monoecious. Flowering is frequent and regular in some cultivars, while in others it is rare or non-existent.

Cassava flowers are borne on terminal panicles, with the axis of the branch being continuous with that of the panicle inflorescence (see Figure 2.3). The male flowers occur near the tip, while the female flowers occur closer to the base. Each flower, whether female or male, has five yellowish or reddish perianths. The male

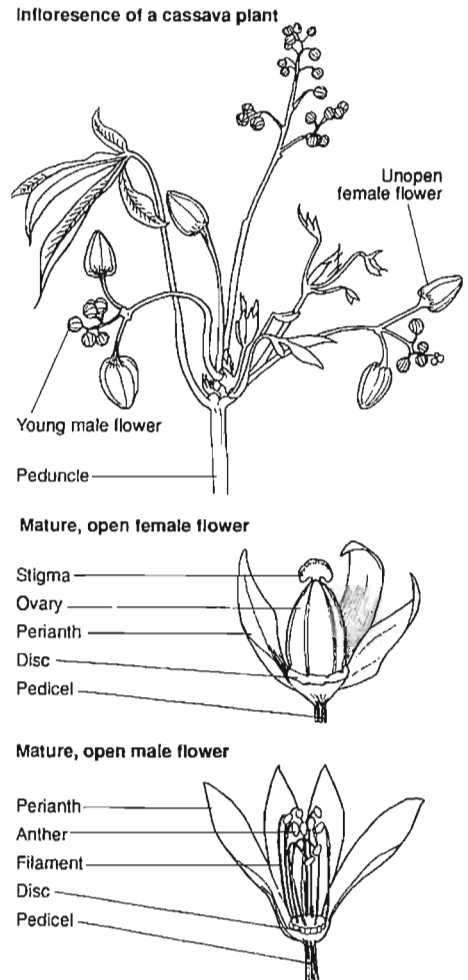
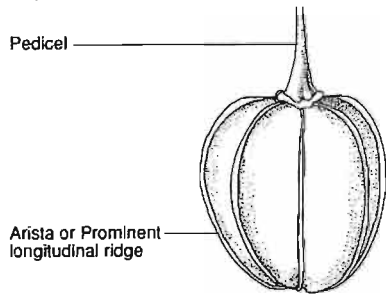
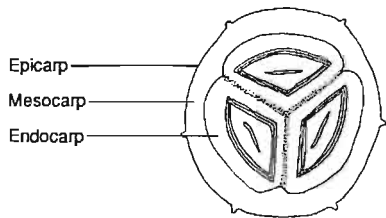

Figure 2.3
Inflorescence of a cassava plant

Mature cassava fruit



Transversal section of cassava fruit showing its tissues



Dry cassava fruit

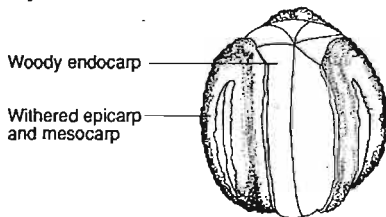

Dehiscence of cassava fruit

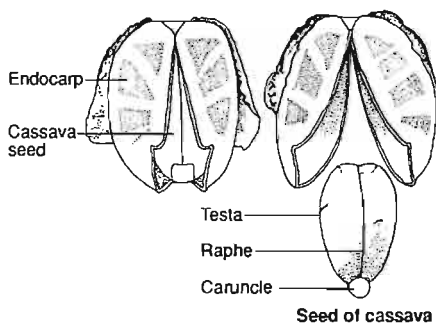

Figure 2.4

Fruit and seed of a cassava plant

flower has 10 stamens arranged in two whorls of five stamens each. The filaments are free and the anthers small. The female flower has an ovary mounted on a 10-lobed glandular disc. The ovary is 3 to 4cm long and has three locules (each with one ovule) and six ridges. The stigma has three lobes which unite to form the single style. The female flowers open first, the male flowers about a week later. Cross pollination is usually the rule.

After pollination and subsequent fertilization, the ovary develops into the young fruit, which takes 70 to 90 days months after pollination to mature (see Figure 2.4). The mature fruit is a globular capsule (diameter 1 to 1.5cm), with six narrow longitudinal wings. The woody endocarp contains three locules, each with one seed. When the fruit is dry, the endocarp splits explosively to release the seeds.

The cassava seed is ellipsoidal and about 1.5cm long. It has a brittle testa which is grey and mottled with dark blotches. There is a large caruncle at the micropylar end of the seed.

Growth and development

At high temperatures (24 to 30°C), the time from appearance to full expansion of a given leaf is about 2 weeks. Leaf growth is greatly reduced at lower temperatures. The size of fully expanded leaves increases with the age of the plant; in most varieties, the leaves reach their maximum size 4 to 5 months after planting, after which the size decreases. There are great differences in maximum leaf size among varieties; individual leaves in some varieties reach 800cm². Leaf size is considerably reduced under adverse environmental conditions, such as nutrient or water stress.

The life of individual leaves is usually 60 to 120 days, but may be as long as 200 days, particularly at low temperatures. Drought and flooding both cause rapid leaf drop, resulting in shorter leaf life. Mutual shading greatly reduces leaf life.

Leaf area index (LAI). This is defined as the leaf area per unit of ground area, and is a measure of the leafiness of a crop. In general, total leaf area depends on:

- rate of formation of new leaves
- size of individual leaves
- longevity of individual leaves

LAI in cassava ranges from 3 to 7, depending on variety. Values above 7 are very rare; the highest LAI ever recorded in cassava is about 10. In many varieties, LAI increases as the number and size of individual leaves increase, reaching a peak 4 to 6 months after planting. Thereafter, leaf size and rate of leaf production decrease and some leaves die; this marks the beginning of the declining phase of LAI (see Figure 2.5).

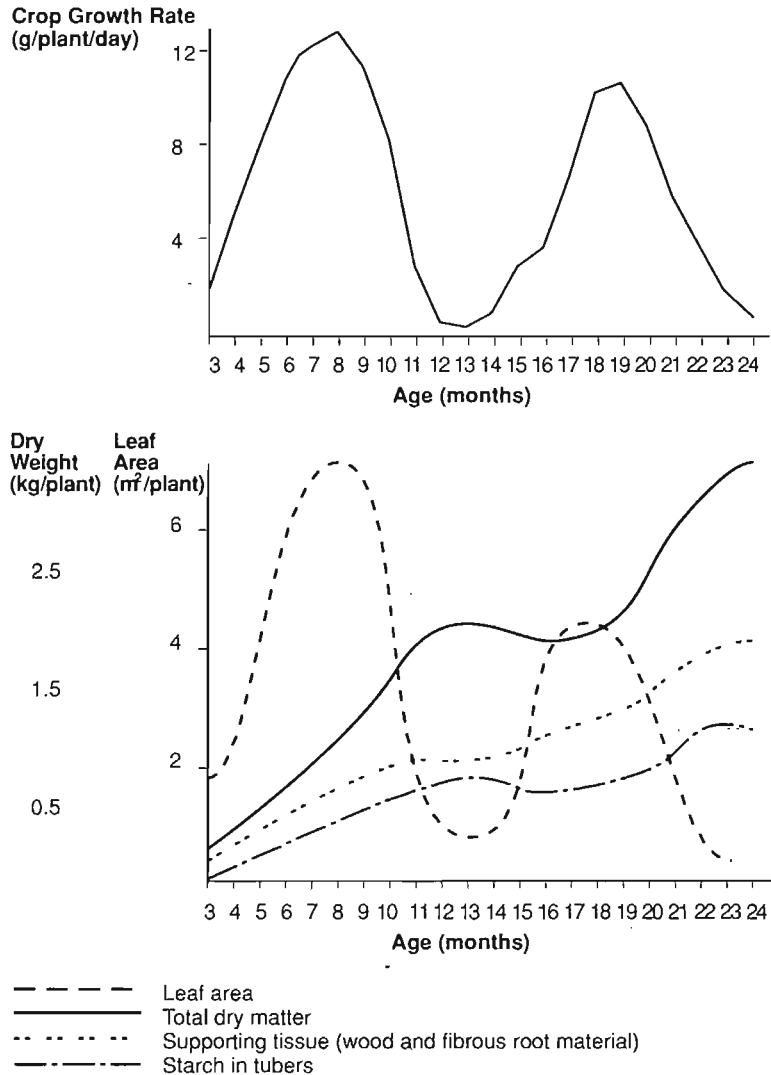

Source: Modified from Cours, 1951

Figure 2.5
Growth and development in cassava

In many cases, the decline in LAI coincides with a dry period. After the rainy season begins, leaf area increases a second time to a maximum which is somewhat less than that of the first season or year. Such a pattern has been observed in some improved IITA varieties. The LAI of TMS 30572, TMS 91934 and TMS 4(2)1425 planted in June increased to reach a peak in October and declined rapidly during the November-March dry season. After the beginning of the rains late in March, LAI increased slightly until harvest time in June. The increase in LAI reflects renewed apical activities when favorable conditions resume.

Leaf area duration (LAD). This is defined as the integral of LAI over time and is an important factor determining tuber yield in cassava. Varieties which have longer LAD and relatively high LAI are usually high yielders. Good examples of long LAD varieties developed at IITA are TMS 91934 and TMS 4(2)1425.

Measurements of photosynthetic rates in cassava leaves show values which range from 15 to 29mg of CO₂ dm⁻² h⁻¹ and 33mg CO₂ dm⁻² h⁻¹. However, recent studies at CIAT using improved techniques have shown values of up to 40mg dm⁻² h⁻¹ and CO₂ compensation point ranging between 50 and 68ppm. This indicates a C₃ photo-synthetic pathway.

Dry matter production and partitioning

The rate of dry matter production follows a similar pattern to that shown by LAI, with values increasing to a peak of about 10 to 12.5g/plant/day after 5 to 6 months. These values represent a Crop Growth Rate (CGR) of 70 to 87.5g/m²/week; this is considerably lower than the 140 to 350g/m²/week reported for some crops.

With a good amount of solar radiation, CGR may attain a value exceeding 120g/m²/week. Values of CGR up to 140g/m²/week have been achieved in some cassava varieties under high radiation intensities and long days.

The optimum LAI for tuber development seems to be between 3 and 5. If that value is maintained, tuber yield can be maximized. At higher LAI, CGR declines mainly because of mutual shading. Root growth rate also declines sharply after LAI exceeds 4 because, at higher values, less photosynthate is available for root growth.

Tuber yield is determined not only by the amount of dry matter produced, but also by the pattern of partitioning of the dry matter

to the different plant parts during growth. In cassava, there is simultaneous development of the shoots and tubers. In other words, assimilate supply is partitioned between growth of the shoots and tubers, and this leads to intensive competition between the different parts of the plants. In general, therefore, to ensure maximum tuber bulking there must be an optimum LAI. If the partitioning of assimilate favors shoot growth, then there will be less dry matter for tuber bulking, which results in low yields. If there is too little assimilate going into leaf growth, then the overall leaf growth will limit photosynthetic production and, again, yields will be low.

This pattern of development differs markedly from that of other crops, such as cereals, in which there is phasic development. In phasic development, the photosynthetic system (leaves) develops first and the storage system (grains) is filled later. Thus, there is little competition for assimilate between the two systems.

The partitioning of dry matter to the various parts of the plant changes considerably during the growth cycle of the cassava crop. For example, allocation of dry matter to the tubers varies from almost none during the early growth stages of the plant to as much as 80% of the daily dry matter production during the late growth stages. Many experiments which have been conducted to determine the pattern of dry matter partitioning to different parts of the plant (the tubers, stems or shoots) have shown that the relationship between total dry weight and tuber weight is linear; this suggests that the tuber bulking rate keeps pace with the rate of crop growth.

In describing this linear relationship, two important parameters have recently been introduced:

- efficiency of tuber production (ETP), which is the regression coefficient of the linear equation between tuber weight and total weight
- apparent initial start of starch accumulation in tubers (AISS), which is the plant weight at which tuber production actually starts

ETP and AISS are now becoming extremely useful as selection criteria for high yield, replacing Harvest Index (tuber weight as a percentage of total weight). This is because ETP is constant for any length of period (Harvest Index is time dependent) and both ETP and AISS give an insight into the growth of cassava before and after the beginning of the tuber filling phase.

Environmental effects on growth and development

Various environmental factors can affect the pattern of growth and development in cassava. Long days, for example, may result in a marked reduction in tuber yield; low temperatures can considerably delay bulking; and drought can hasten the declining phase of LAI. In general, however, cassava can be grown in areas where the annual rainfall ranges from 600 to 750mm and can survive in areas with dry seasons as long as 6 to 8 months. Because of such hardiness, farming families in semi-arid areas rely on cassava as a 'famine crop' during the dry season or in times of drought.

Cassava is able to grow under such extreme conditions because it has a very conservative pattern of water use. At the onset of a dry season, the production of new leaves is reduced drastically, which in turn reduces transpiration. The stomata close as soon as they are exposed to dry air, which reduces water loss at the time when evapotranspiration is greatest. The reduced leaf area and the stomata closure reduce CGR during periods of drought.

Other mechanisms ensure that plant growth is not drastically affected under drought conditions. These are:

- a heliotropic response mechanism, which allows cassava leaves to maximize interception of available sunlight at times when transpirational demands are low (for example, in the morning and late afternoon the leaves usually turn to face the direction of the sun)
- a drooping mechanism, which causes the leaves to droop during daily peaks of heat; this reduces the heat load on the leaves when the heat is greatest
- an increase in the partitioning of dry matter to the feeder root system when plants undergo long periods of drought, which enhances the plant's exploitation of soil moisture

UNIT 3

Breeding

The goal in cassava breeding is to develop varieties which combine high and stable yields with good quality characteristics relevant to the ways in which the crop is utilized in specific regions.

The objectives of a cassava breeding program should usually include:

- high yield in terms of dry matter per unit of land area per unit time
- resistance to the major diseases prevalent in target areas (for example, ACMV, CBB and CAD)
- resistance to the major insect pests in target areas (for example, CM and CGM)
- improved quality in terms of local consumption requirements (for example, low cyanide and mealy varieties in areas where the roots are boiled and eaten without further processing)
- adaptability to environmental conditions and cropping systems in target areas
- improved plant characteristics in terms of canopy and roots

Breeding procedures

Germplasm collection and evaluation

The most important tasks in any cassava breeding are the acquisition and selection of superior breeding material. In Africa, there

is considerable variability among the local germplasm collections. There are two reasons for this. Firstly, some of the materials flower and set seed freely, and new cultivars are established from volunteer seedlings; because cassava is a cross-pollinated crop, continuing recombination and variation occur from outcrosses of genetically heterozygous cultivars. Secondly, spontaneous mutation may give rise to additional genetic variation, although this has not been proven.

Many of the local cultivars flower well. However, some flower only to a limited extent ('shy flowering') and others do not flower at all under normal growing conditions; this makes their exploitation in a breeding program rather limited.

The systematic introduction of new breeding material from other cassava programs (for example, from national or IITA programs) is desirable, especially from areas of similar ecological conditions. The African Phytosanitary Council regulations require that introductions of new breeding material from outside Africa be confined to true seed which has had appropriate chemical and physical treatments. However, the movement within the continent of tissue culture material which is indexed as being free of pathogens, particularly ACMV, is permitted by the Council through appropriate phytosanitary channels. This is important in order to minimize introduction of new diseases and pests in vegetative materials.

Both the clones developed by a breeding program and those from exotic introduction in seed form need to be evaluated in order to identify their potential as breeding materials or as varieties in terms of their agronomic characteristics. The agronomic characteristics include resistance to diseases and pests, characteristic plant architecture, yield, tuber quality, cyanide content, adaptation to agroecological zone and any additional locally important traits.

The germplasm may be conserved as clones in field plots, as meristem tips in vitro, and/or as seeds in low temperature and humidity conditions.

Source population

The source population for improvement is made up of genotypes which have genes associated with desirable characteristics. The population may be improved through cyclic recombination and selection procedures while retaining a high degree of genetic variability. Conventional methods of creating source population can also be used by making crosses between two selected parents.

Seed production

As indicated in Unit 2, the stamens and pistils of cassava flowers are located in separate flowers on the same inflorescence. The female flowers are large, are nearly always located at the base of the inflorescence, and open first, the male flowers are small, are located at the apical portion of the inflorescence, and usually open about 1 week after the female flowers. Under normal conditions, the stigma remains receptive for up to 24 hours after the opening of the flower and dried pollen remains viable for about 6 days under controlled conditions.

Both the stigma and pollen are sticky, and pollination is easily carried out by honey bees. Structurally and functionally, therefore, the cassava flower is well adapted to cross-pollination.

In the northern hemisphere, cassava usually flowers from July to January, with a peak between September and November. In the southern hemisphere, it usually flowers from January to July, with a peak between March and May. The time of flowering, however, depends to a large extent on rainfall distribution, day-length and temperature.

In general, there is a vegetative phase of 1 to 4 months in most cultivars that flower under natural conditions, making it important to plant cassava at least 4 months before the peak flowering period. In order to synchronize the flowering periods of different cultivars or clones, parental genotypes should be planted every 2 to 3 months because flowering on an individual plant usually lasts for more than 2 months.

For pollination by hand, pollen is collected early in the morning before 10.00h and pollination made before 13.00h. Both male and female flowers that are on the point of opening are used. When the anthers are mature, they change from green to yellow, and this change in color is a useful indication of when pollen can be collected.

Pollination can be made by hand using the male flower after removing the perianth or, for mass pollination, by using an applicator. The applicator can be made from a stick with the tip covered with an adhesive piece of velvet-like material to which the pollen will readily adhere (see Figure 3.1). Several flowers can be pollinated without recharging the applicator. If the applicator is to be used for other pollen parents, it should be sterilized; this is done by dipping it into alcohol before using it for new parents. The pollinated flowers are bagged with cloth or paper bags (white) to



Figure 3.1
Pollination by hand

protect them against bees or other insects carrying foreign pollen (see Figure 3.2); the bags are removed 5 days later.



Figure 3.2
Bagged pollinated flowers

Because cassava is normally a cross-pollinated plant, outcrossing can occur among selected parents in isolation. There should be 1 to 3 selected parent genotypes per isolation plot, with several replications to provide an equal chance of crossing.

Seeds mature about 70 to 90 days after pollination. The fruits are collected when the coats begin to shrivel and are dried under the sun or in an oven at 40 to 50°C until they shatter. Fruits from isolation plots are collected in cloth bags hung on cassava plants for each variety or clone and left there until they shatter, releasing hybrid seeds which are ready for germination.

Seed germination and transplanting

Cassava seeds have a very short dormancy period or, in some cases, none at all. Seeds germinate quickly at optimal soil temperatures (30 to 35°C) and moisture regimes. Scarification is usually unnecessary, but seeds from related wild species can be scarified by rubbing them gently on the micropyle with a rough stone or sandpaper.

Seeds may be sown in peat pellets, jiffy pots or plastic bags arranged on nursery beds during the dry season. During the first

3 weeks, the nursery beds are irrigated twice daily, in the mornings and afternoons; thereafter, they are irrigated at regular intervals until the transplanting stage. If irrigation is not possible, seeds can be planted soon after the first rain. The seeds germinate from 10 to 30 days after planting and are ready for transplanting when they are from 15 to 20cm high (*see* Figure 3.3). Because cassava seedlings are weak and grow slowly, weed control is very important at the early stages of growth to offset competition.



Figure 3.3
Seedlings growing in nursery

The field into which the seedlings are to be transplanted is plowed, disc harrowed, and divided into 5m-wide beds; if erosion is not a problem, the field may be flat with no beds. The seedlings are planted at 40cm x 50cm and irrigated until the rains begin. Wider spacing can be used if land and labor are not constraints. As many as 50 000 seedlings may be produced in any one year.

Breeding scheme

To achieve the program objectives, the IITA breeding scheme may be modified to suit local conditions (*see* Figure 3.4 *overleaf*).

First year. During the growing period, the seedlings are screened for resistance to the major diseases and insect pests at 1, 3, and 6 months after planting in the field. In the case of ACMV, the seedlings are exposed to a high population of whitefly (vector of ACMV) from spreader varieties planted alongside the nursery. If

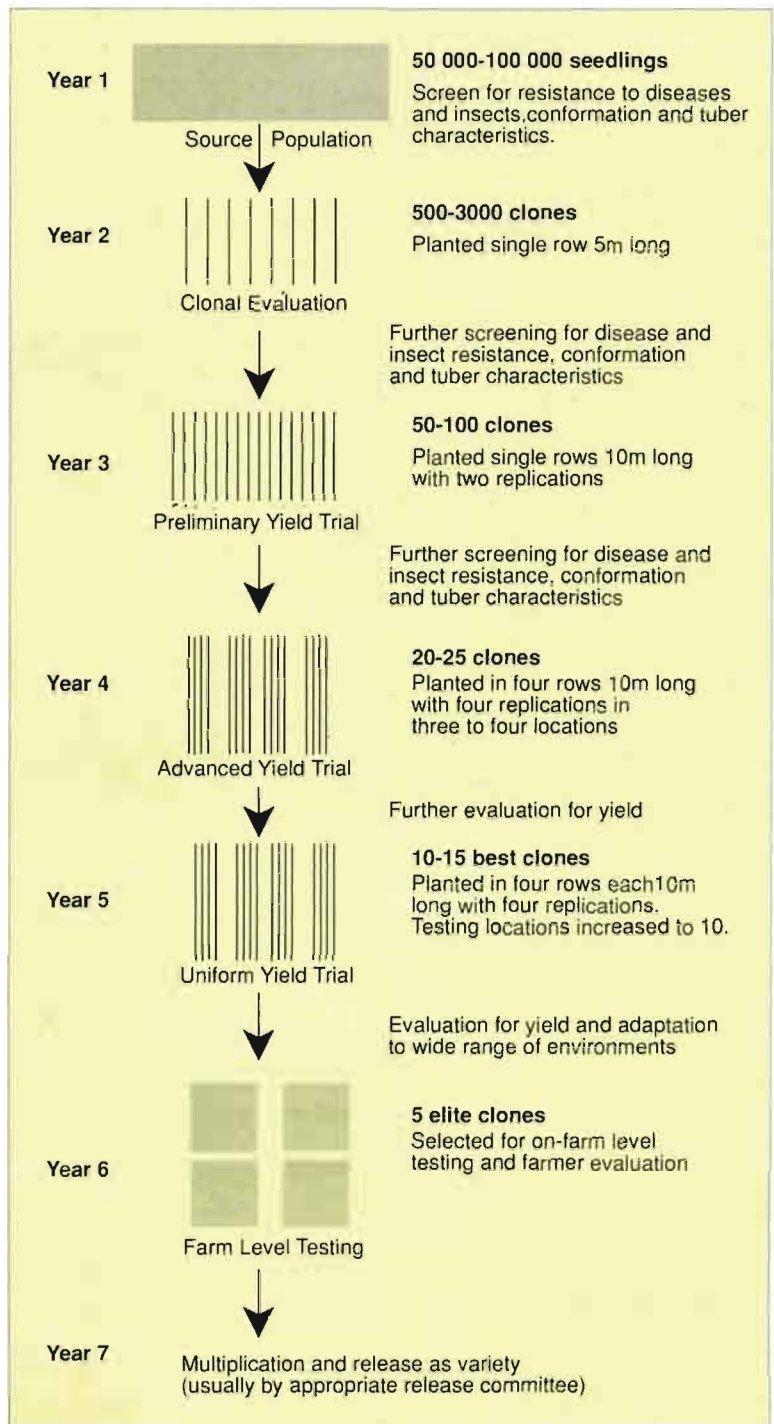

Figure 3.4
IITA cassava breeding scheme

environmental conditions are favorable for disease development, the seedlings are also screened for resistance to CBB under natural epiphytotic conditions; if not, they are inoculated with CBB inoculum using a stem puncture method. Seedlings are also screened for pubescence, which is associated with resistance to CM and CGM. Towards the end of the rainy season, they are cut back to induce the production of young shoots and are screened for resistance to CM and CGM. Resistant seedlings are selected and tagged.

At 3 months after planting, seedlings are also tested for cyanide levels using the leaf picrate method, and the low-cyanide seedlings are selected. Seedlings with a low branching habit (branching heights of below 50cm), which is associated with early flowering, are discarded. At 12 months, all the selected materials are harvested and further selection is made based on tuber shapes, tuber size, number of tubers per plant, neck length and poundability. The seedlings with a short neck (1 to 3cm) and uniform short, compact, fat tubers are selected.

Second year. The selected seedlings, which may number up to 3000, are cloned and planted for clonal evaluation in a single row plot of 3 to 5 plants, at 1m² spacing. A standard local variety is planted every 10 clones for comparison. At this stage, the observations made during the first year on diseases, pests and conformation are confirmed for each clone; at 1, 3 and 6 months after planting, each clone is scored for ACMV and CBB. Later in the year, the clones are also assessed for insect damage, particularly by CM and CGM. Agronomic characters such as branching height and angle, canopy spread and the number of stems per plant are also scored.

At harvest (12 months after planting), the individual clones are again assessed on the basis of the number of plants which have survived, the number of tubers per plant, tuber shapes and size, tuber neck-length, total tuber yield (kg/plot) and the overall appearance of the tubers. The clones which perform poorly in terms of establishment, growth and resistance to diseases and insect pests are discarded. Only promising clones are further evaluated for dry matter, yield potential and other quality characters. Clones selected for low-cyanide content are further evaluated quantitatively for cyanide, using the leaf picrate method or an enzymatic assay method.

Third year. The best 50 to 100 clones selected through clonal evaluation in the previous year are put through a preliminary yield trial in single rows 10m long with two replications. At this stage, the

clones are evaluated again for yield, disease and pest resistance, tuber characteristics, conformation, dry matter and consumer acceptance qualities.

Fourth year. The most promising 20 to 25 clones from the preliminary yield trial carried out during the third year are moved to an advanced yield trial in four rows, each 10m long, with four replications. Only the two central rows of each plot are harvested for yield estimation. The trials are conducted at three or four locations, representing a wide range of environments. The clones are further evaluated for tuber yield, disease and pest resistance, dry matter content, consumer acceptance qualities and ecological adaptation.

Fifth year. Based on performance in the advanced yield trial of the previous year, the best 10 to 15 clones are advanced to a uniform yield trial. The number of testing sites is increased to 10 and the clones are thoroughly evaluated for yield, dry matter content, consumer acceptance qualities and ecological adaptation. The trials are planted in four-row plots, each 10m long, with four replications at each location. Only the two central rows of each plot are harvested for yield estimate.

Sixth and seventh years. Uniform yield trials may be carried out for a further year or two in order to confirm the adaptability of the clones in the various locations. However, during the sixth year, five elite clones from the uniform yield trial are advanced to farm-level testing with farmers' participation.

Clones found to be most popular with farmers are multiplied during the seventh year. They are subsequently distributed through established national channels.

UNIT 4

Rapid Multiplication

The phrase 'multiplication ratio' refers to the increase in planting material over what is planted. Cassava is a vegetatively propagated crop with low multiplication ratios. For example, when a cassava stem cutting (25 to 30cm long) is planted, it gives about 10 stem cuttings 12 months later; thus the multiplication ratio is 1 : 10. This is low compared with a maize plant which may yield a cob with about 300 seeds (multiplication ratio 1 : 300).

The phrase 'rapid multiplication' is used to describe a technique for overcoming the handicap of low multiplication ratios in vegetatively propagated crops. It involves using improved techniques to rapidly increase the quantities of planting materials from what is available.

In addition to increasing the multiplication ratio of cassava, rapid multiplication technique may also be used in other cases.

1. National programs and international agricultural centers, such as IITA, which are involved in cassava breeding can increase the few plants of an improved variety through the rapid multiplication technique. This 'breeder seed' is high yielding, disease- and pest-resistant and of high quality. Institutions, including national seed companies, and farmers who receive breeder seed can also multiply materials supplied to them through this technique.
2. At certain stages in the breeding program, it is necessary to evaluate the materials in multilocational trials or in on-farm trials in several locations. The rapid multiplication technique may be used to produce enough healthy materials for such trials. Researchers plant special multiplication plots to produce such materials for the following year's trials in a process known as 'back-up multiplication'. The materials produced may also be used in other trials (for example, agronomic trials).

3. Healthy, improved clones which are received by national programs from research centers may be multiplied using the rapid multiplication technique in order to generate enough materials for national evaluation. Vegetatively propagated crops such as cassava cannot be transferred across international borders unless they have been certified by the Plant Quarantine Service as being free from diseases and pests. IITA has perfected its tissue culture techniques which are used to produce and multiply disease- and pest-free cassava plantlets for distribution to national programs with which the center is collaborating. This material first has to be evaluated throughout the country by the national program before it can be recommended for adoption. The evaluation requires a lot of planting materials, which can be obtained through rapid multiplication.
4. The rapid multiplication technique may be used to multiply quantities of improved varieties available for distribution to farmers in areas where major disease and pest outbreaks, such as CBB and CM, have wiped out several hectares of susceptible cassava varieties.

Principles of rapid multiplication

The rapid multiplication technique utilizes certain basic morphological characteristics of the cassava plant. Examples of these characteristics are the dormant axillary buds which are located at the nodes, and the fact that the lowest portion of the stem is oldest, has a greater diameter and more food reserves, and is harder than the other portions of the stem; in a typical cassava stem the hardwood, semi-mature and soft green portions are easily distinguished.

The basic principles of rapid multiplication of cassava are:

- each axillary bud on the stem can develop into a shoot if apical dominance is removed
- the whole stem of the plant is utilized
- stem production is the main goal
- only healthy, disease- and pest-free stems are used for multiplication
- healthy planting materials are produced

Rapid multiplication technique

Preparation of ministem cuttings

The stem is cut into several small pieces. Each piece should have one or more nodes, depending on the portion of the stem from which it is cut. Those pieces cut from the hardwood portion may have one or two nodes; those from the semi-mature portion may have four to six nodes; and those from the tip portion may have six to ten nodes. The number of nodes on a cutting is not rigid and depends on such factors as internode length, diameter, age of the plant, and weather conditions at and after planting.

These stem pieces are termed 'ministem cuttings'. Those cut from the hardwood stem portion are called 'hardwood ministem cuttings'; those from the semi-mature portion are called 'semi-mature ministem cuttings'; and those from the top green stem portion are called 'tip shoots' or 'tip shoot ministem cuttings' (see Figure 4.1).



Figure 4.1

Ministem cuttings: tip shoot (left), semi-mature (center) and hardwood (right)

The hardwood and semi-mature ministem cuttings are prepared using shears, secateurs, a machete or a hand saw; the tip shoots are prepared using secateurs or sharp knives (see Figure 4.2). Tools must be sharp to ensure cleanliness of the cut ends. The tip



Figure 4.2
Examples of tools used to prepare ministem cuttings: shears (left), secateurs (center) and a hand saw (right)

shoots are stripped of all leaves, except the youngest, and kept in water until planted in order to prevent dehydration.

Planting ministem cuttings in the nursery

Ministem cuttings can be planted in nursery beds with well-drained soils near a source of water, or in strong black polyethylene bags which have been filled with good-quality garden soil and perforated on the sides and at the bottom to facilitate drainage. Poor-quality bags may break when they are filled with soil or moved from one location to another.

Hardwood ministem cuttings. These cuttings are planted, either in nursery beds at a spacing of 10 x 10cm or in black polyethylene bags, at a depth of about 4 to 5cm. Cuttings which are planted too shallow are exposed after water has been applied a few times and become dehydrated.

The orientation of the cuttings is such that two opposite nodes are on the right and left sides when buried. This is to avoid the placement of one of the nodes at the deepest level, as shoots developing from such nodes struggle to emerge and are usually weak and fragile at the base. Such weak seedlings break at transplanting.

Semi-matured ministem cuttings. These cuttings are usually 7 to 10cm long, and are planted vertically at a spacing of 10 x 10cm



Figure 4.3
Semi-mature ministem cuttings planted in a nursery bed

in the nursery beds or in polyethylene bags filled with soil, with two-thirds of each cutting buried in the soil. The oldest end of the cutting is the buried portion. Figure 4.3 is an illustration of semi-matured ministem cuttings planted in a nursery bed.

Tip shoot ministem cuttings. The tip shoot ministem cuttings are planted in a similar manner to the semi-matured cuttings, at a spacing of 10 x 10cm with two-thirds of each cutting buried in the soil. They can be planted in nursery beds or in polyethylene bags filled with soil.

Nursery maintenance and care

The following steps are recommended for proper nursery maintenance and care of planted cuttings:

1. Apply water to the nursery beds and the potted plants immediately after planting. Thereafter, limit the application of water to twice a day, once in the morning and once in the evening. Soil and atmospheric conditions can affect the frequency of water application (for example, after a good rain it may not be necessary to apply water as too much water may cause some cuttings to rot).
2. Provide labels stating the variety and date of planting for each nursery bed or group of potted plants.
3. Remove by hand any weeds which appear in the beds or the bags.
4. Cover with soil any cuttings which are exposed as a result of water application.



Figure 4.4
Hardwood ministem cuttings showing root and shoot growth (planted horizontally)



Figure 4.5
Semi-mature ministem cuttings showing root and shoot growth (planted vertically)

Sprouting and establishment

The ministem cuttings (especially the hardwood and the semi-matured cuttings) sprout 7 to 10 days after planting. Fibrous roots develop at the buried nodes and at the oldest ends of the cuttings. The shoots later emerge from the soil and continue to develop leaves (see Figures 4.4, 4.5, 4.6 and 4.7)

The highest plant establishment is obtained from hardwood cuttings; tip shoot cuttings usually give the lowest establishment. Tip shoots prepared from field plants usually perform poorly because they are very young and can dehydrate or rot easily; however, they



Figure 4.6
Semi-mature ministem cuttings
growing in polyethylene bags

can be prepared from shoots which develop from the planted ministem cuttings 8 to 10 weeks after planting in the nursery.



Figure 4.7
Semi-mature ministem cuttings growing in the nursery

Transplanting

After they have been in the nursery for 4 to 6 weeks, the ministem cuttings are transplanted into the field. Transplanting is carried out in the dry season using irrigation, or in the rainy season when no irrigation is necessary. Waterlogged fields are avoided; the percentage of survival or establishment is low in such fields because of poor aeration and poor root development. Removal of the plants from the nursery beds is done carefully, using trowels or hand-forks to avoid damage to the roots.

The following operations are performed before the sprouted plants are removed from the nursery:

1. The plants are hardened by reducing the amount and frequency of water application 1 to 2 weeks before transplanting.
2. Water is applied heavily on the evening before transplanting.
3. Water is then applied again in the morning on the day of transplanting.

4. The field is prepared and made ready for transplanting by one of the following methods: plowing and harrowing; slashing the top growth and applying herbicides to kill the vegetation; or laying plastic mulch after either of the above preparations (irrigation is used before laying the plastic mulch if transplanting is done in the dry season).

The spacing between plants is either 100 x 50cm or 50 x 50cm. For transplanting potted plants, holes must be dug after the desired spacing is marked because a ball of soil is retained with the plant. The soil around each transplanted plant is firmed and the plot is then labeled with a signboard showing the variety, date of planting and number of hectares planted.

Field maintenance

Proper field maintenance after transplanting is essential if strong, healthy planting materials are to be produced.

Weed control must be properly carried out during the first 10 weeks, using such methods as hoeing or applying herbicides. With the use of plastic mulch, weeding is limited, but any weeds that develop near the plants must be removed. At transplanting, the holes cut through the plastic mulch for planting must be small to prevent heavy weed growth.

Other advantages of laying plastic mulch are that:

- it allows larger hectares of land to be put under cassava multiplication with greater success because it ensures both good plant establishment and vigorous plant growth, particularly in the initial growth stages; the advantage of limited weeding which is associated with the use of plastic mulch encourages the planting of large hectares to cassava for multiplication
- there is a higher yield of cassava stems
- soil erosion is reduced and thus there is better soil moisture conservation

Rogueing the off-types (or mixtures) is done during the early stages and any vacancies created as a result of the death of some plants are filled. This promotes better canopy cover, which in turn helps suppress weed growth. Fertilizer (NPK) is applied where necessary.

New rapid multiplication technique

The rapid multiplication method discussed above is a widely used and effective method. Latest research, however, has resulted in a major improvement: *ministem cuttings can be nursed in polyethylene bags without soil, thus providing a quicker, less expensive and more convenient method.*

Under the method described above, ministem cuttings are nursed for 4 to 6 weeks in polythene bags or nursery beds filled with garden soil before they are transplanted into the field. Large quantities of soil (over 5 tons on an oven-dried basis) are needed to nurse cuttings for planting in 1 hectare, and the soil usually has to be excavated from another site and transported to the nursery. About 50 man-days are required to fill the bags with soil to nurse cuttings for planting in 1 hectare; additional labor is needed to plant one cutting per bag (20 000 or more plants per hectare) and to care for the plants prior to transplanting.

The planting materials are bulky and heavy to transport to the field, and the soil used could carry disease-causing organisms such as nematodes, fungi and bacteria. Sterilizing the soil to overcome this problem is expensive and facilities to do this are not easily available.

With the new rapid multiplication technique, the ministem cuttings are dipped into a fungicide/water suspension. They are then put directly into perforated polyethylene bags and stored in a shaded area or under a roof. The bags are tied with pieces of string, leaving about one-third of the top space empty to allow for aeration. Various sizes of bags can be used, as long as they are not completely filled.

Depending on the cassava variety, 95 to 100% sprouting occurs in 3 to 5 days. In an experiment carried out in Togo, 100% sprouting was achieved with the variety 'Nakoko' in 2 or 3 days, but some varieties may require a few more days to give a high percentage of sprouting. High humidity and temperature inside the polythene bag promote a rapid and uniform sprouting. In recent experiments, the sprouted ministem cuttings established well in the field at 8 weeks after transplanting, as shown in Table 4.1.

The new technique has other advantages: the ministem cuttings can be stored for a few days, fairly large numbers can be carried by hand or transported over long distances with a limited space requirement, and they can be used for mechanical planting.

Table 4.1**Percentage of field establishment for cassava ministem cuttings pre-sprouted in perforated polyethylene bags**

Cassava variety	Condition of materials before transplanting	Number of ministems planted	Percent establishment (8 WAT)*
TMS 4(2)1425	Sprouted with shoots and roots	950	89.3
TMS 4(2)1245	Sprouted with shoots only	1260	89.4
TMS 50395	Sprouted with shoots only	420	86.9

Note: WAT = weeks after transplanting

Source: IITA Annual Report and Research Highlights, 1987/88

Harvesting the stems

If the field is maintained properly, stems can be cut and supplied to farmers or institutions from 6 to 7 months after transplanting. As the objective of rapid multiplication of cassava is to produce stems, the plants are not uprooted at harvest. They are cut at a height of 20 to 25cm from the ground after it has been ascertained that they are physiologically mature and pest- and disease-free.

This practice of leaving the stumps standing in the field after harvest is known as 'ratooning'. Several shoots sprout from a ratoon left in the field but these are reduced to two or three. Herbicide and fertilizer are applied to the ratooned plots. Another set of stems is cut again about 6 months later. At IITA, as many as three ratoons have been taken from rapid multiplication plants. The number of ratoons is influenced by several factors, including variety, soil type and fertility, weed control and field maintenance.

After harvest, the stems are tied together in bundles; in Nigeria, these bundles consist of 50 stems, each 1m long, and it is in this form that the stems are sold. Stems must be handled with care throughout the harvesting, loading, transporting and unloading procedures, to avoid too much bruising. If axillary buds are bruised, they may never develop into plants if the nodes are used in rapid multiplication.

Distribution

Multiplication of planting materials *per se* is not enough unless steps are taken to ensure their effective distribution to the farmers or institutions for whom the materials were multiplied. Cassava stems are bulky and do not store well for a long time. Their transportation and distribution, therefore, deserve special effort by those people who are responsible for making the materials available to farmers. Some farmers who need the improved varieties will go to the sources of supply and collect them. Many farmers, however, lack the means to go to the sources or may not be aware of the existence of superior varieties.

Planting materials can be effectively distributed using one or more of the following channels:

- special government and/or donor-assisted agricultural or multiplication projects
- strategically located National Seed Service multiplication centers of Ministries of Agriculture
- private and mission agricultural projects
- school farming projects
- agricultural meetings (such as in-country training courses, farmers' field days and agricultural shows)
- transporting planting materials in trucks and vehicles to villages and farms
- demonstration plots
- multilocational on-farm trials where the varieties are supplied to farmers for testing, with the farmers retaining the good varieties
- farmer-to-farmer movement of planting materials

Storage

As planting materials, it is important for cassava stems to be properly stored. Long-term storage is not possible because stems dehydrate during storage. They are also attacked by insects and diseases, which results in a lower sprouting percentage.

Storage of cassava stems is necessary when:

- the plants are harvested for tubers off-season and the stems need to be preserved for planting some weeks later
- a farmer acquires stems for planting before his/her field is ready for planting
- the stems, especially of improved varieties, are sold by farmers on the roadside and thus must be stored properly during the period of sale

Storage methods

Cassava stems can be stored effectively in one of three ways.

The stems are tied into bundles and stored upright under a roof, in a well-ventilated shed or under a well-developed tree providing good shade (see Figure 4.8). The oldest ends of the stems are inserted in soil, and water may be applied to the base. Stems can be stored in this way for up to about 8 weeks.

2. The oldest ends of 1m-long cassava stems are inserted upright into the soil in a cool, well-shaded area. The basal portions of the stems should touch each another. The stems are inserted so that they lean on a strong support (a tree stem or bamboo stick) which has been tied horizontally between two trees a few meters apart (see Figure 4.9).
3. Stems are stored horizontally under well-developed tree shade for up to about 8 weeks.



Figure 4.8

Cassava stems stored upright



Figure 4.9

Cassava stems stored on a horizontal support system

Precautions

When storing cassava stems, there are a number of important points to be borne in mind:

- avoid direct sunlight and hot or cold winds
- let the buds face upwards when stems are stored vertically
- long stems store better than short ones
- use mature stems from healthy cassava plants or plantations
- the viability of stems under storage depends on a number of factors, including the variety, the storage methods and conditions, the length of storage and the quality of planting material

UNIT 5

Tissue Culture

Tissue culture is a means of growing a plant's cells or tissues under controlled conditions. It may be defined as the culture of single plant cells, a group of cells, tissues or organs in an artificial environment under aseptic conditions. Within such an environment, the cells, tissues and organs multiply and continue to grow in an unorganized way or regenerate into a whole plant. The phrase *in vitro*, which means 'growing outside the living body, in an artificial environment' is often used in association with tissue culture.

The traditional method of propagating cassava is by using stem cuttings. However, the risk associated with this method is that many diseases and insects persist in the stem cuttings and are carried over from one vegetative generation to the next; examples of such diseases are ACMV and CBB. This has important implications in the collection and maintenance of healthy germplasm for breeding purposes and the movement of cassava clones across national borders.

In the traditional approach, germplasm collections of vegetatively propagated crops are grown in the field each season. This requires many hectares of land, involves considerable labor costs and leads to a significant loss of germplasm materials as a result of insect damage, disease attack and other unpredictable environmental factors.

In comparison, tissue culture offers safe storage and maintenance of germplasm in an *in vitro* environment. *In vitro* rapid multiplication can produce large amounts of planting material and is not restricted by seasonal changes.

Meristem and/or shoot-tip culture is the most effective method for virus elimination in a wide range of crop species. When placed on a suitable culture medium and incubated under favorable condi-

tions, the isolated meristems regenerate into plantlets. Using various virus indexing methods, the regenerated plants are then indexed for freedom from virus infections. Plants which are regenerated in this way usually retain the characteristics of their mother plant, thus making this a very useful method for cleaning up disease-infested material for distribution.

Culture media composition

The composition of culture medium is one of the most important factors that determines the success of the culture.

The components of plant tissue culture media include inorganic salts, plant growth regulators, vitamins, amino acids, complex organic supplements, carbohydrate, distilled water and the medium matrix.

There are a number of formulated media which are used in either basic or in modified form by tissue culture workers. Some of these formulated media, including Heller's, Nitsch's, White's and Murashige and Skoog's media (MS), are commercially manufactured. Others may be prepared by using stock solutions, examples of which are presented below.

Composition of stock solutions for the MS medium

The MS medium consists of more than 15 different chemicals. The quantity of each chemical required for the preparation varies; in the case of some chemicals, the requirement is minute.

Stock solutions which are prepared at a higher concentration (10 or 100 times) are therefore used to increase accuracy and convenience when preparing media.

Stock solution I

	mg/l		
NH_4NO_3	33000	=	33g
KNO_3	38000	=	38g
$\text{CaCl}_2 \cdot 2\text{H}_2\text{O}$	8800	=	8.8g
$\text{Mg SO}_4 \cdot 7\text{H}_2\text{O}$	7400	=	7.4g
$\text{K H}_4 \text{ PO}_4$	3400	=	3.4g

Stock solution II

	mg/l		
KI	160	=	0.16g
H ₃ BO ₃	1240	=	1.24g
MnSO ₄ ·4H ₂ O	4460	=	4.46g
ZnSO ₄ ·7H ₂ O	1720	=	1.72g
Na ₂ MoO ₄ ·2H ₂ O	50	=	0.05g
CuSO ₄ ·5H ₂ O	5	=	0.005g
CoCl ₂ ·6H ₂ O	5	=	0.005g

Stock solution III

	mg/l		
Fe SO ₄ · 7H ₂ O	5560	=	5.56g
Na ₂ · EDTA· 2H ₂ O	7460	=	7.46g

Vitamin mixture stock solution

	mg/500ml		
Thiamine hydrochloride	10	=	0.01g
Pyridoxine	50	=	0.05g
Nicotinic acid amide	50	=	0.05g
Glycine	100	=	0.1g

Stock solution for growth regulators

Most of the growth regulators dissolve in dilute NaOH or HCl, 95% ethanol or distilled water with heating.

NAA stock solution. Using an analytical balance, weigh 10mg of NAA and dissolve it in a few drops of 0.5N NaOH. Add distilled water to make the solution up to 100ml. Mix the solution well and store the mixture in a refrigerator. The solution gives 0.1 mg of NAA per ml of solution used.

BAP and GA₃ stock solutions. Measure 10mg of the respective chemicals and dissolve them separately with 95% ethanol. Add distilled water to make the solution up to 100ml. Mix the solution well and store it in a refrigerator. The solution gives 0.1 mg of BAP or GA₃ per ml of solution used.

Dilution of stock solution of growth regulators. If the quantity required is less than 0.1 mg, the solutions are diluted by 10 or 100 times, to give more accurate measurements.

Modified forms of the MS media are commonly used for tissue culture. The following are used for cassava meristem culture.

**Cassava meristem culture medium
(for 1 liter medium)**

Stock solution I	50 ml
Stock solution II	5 ml
Stock solution III	10ml
Vitamin stock solution	5ml
Sucrose	30g
Inositol	100mg
Adenine sulfate	80mg
Naphthalene acetic acid (NAA)	0.2mg
Benzyl amino purine (BAP)	0.15mg
Gibberellic acid (GA ₃)	0.02 mg
Agar	7g

Multiplication media for cassava are simpler than the media used for meristem culture because the size of the plant material used in multiplication is much larger.

**Multiplication medium for cassava
(for 1 liter medium)**

Stock solution I	50ml
Stock solution II	5ml
Stock solution III	10 ml
Sucrose	30g
Vitamin stock solution	5ml
Inositol	100mg
NAA	0.01mg
BAP	0.05mg
Agar	7g

Culture media preparation

If a commercially produced medium is not used, stock solutions of macro-elements, micro-elements, vitamins and growth regulators are prepared and stored in the refrigerator, while vitamins must be

kept in the freezer. The chemicals used for such preparations are of analytical grade, and double distilled water is used to ensure that the purity of the medium is improved. However, for routine tissue culture work, refined grocery sugar is generally sufficiently pure and can be used as a carbon source instead of sucrose. Examples of culture medium preparation are presented below.

A. Procedure for media preparation using a ready-made medium package (1 pack for 1 liter culture medium)

1. Dissolve the powder in 500ml of distilled water in a 1-liter beaker
2. Add 30g sucrose
3. Add additives (e.g. growth regulators NAA 0.1mg, BAP 0.05mg, GA₃ 0.02mg)
4. Add distilled water to over 900ml mark
5. Adjust pH to 5.7±0.1 with dropwise of 0.5N NaOH or 0.5N HCl
6. Make up final volume to 1 liter
7. Put solution in erlymeyer flask(s) and add 0.6 to 1% agar if solid medium is preferred
8. Melt the agar
9. Distribute to culture tubes
10. Autoclave at 121°C for 15 minutes (if to be poured into pre-sterilized culture containers, media are autoclaved first for 15 to 20 minutes)
11. Let cool and solidify

B. Procedure for the preparation of culture media using a plant salt mixture package (1 pack for 1 liter culture medium)

1. Dissolve powder in 500ml of distilled water in a 1-liter beaker
2. Add 5ml vitamin stock solution
3. Add 100mg inositol
4. Follow the rest of the procedure in A from step 2

C. Procedure for the preparation of culture media using stock solutions (to prepare 1 liter of culture medium)

1. Fill a 1-liter beaker with 200 to 300ml distilled water
2. Pipette in 50ml of stock I
3. Pipette in 5ml of stock II
4. Pipette in 10ml of stock III
5. Follow the rest of the procedure in B from step 2

After autoclaving, the culture media are stored in a transfer room or in a refrigerator in a plastic bag. Some of the additives which are heat labile and not suitable for autoclave can be sterilized using an autoclaved millipore filter.

Procedure for cassava meristem-tip culture technique

The procedure for cassava meristem-tip culture technique is described here (see Figure 5.1).

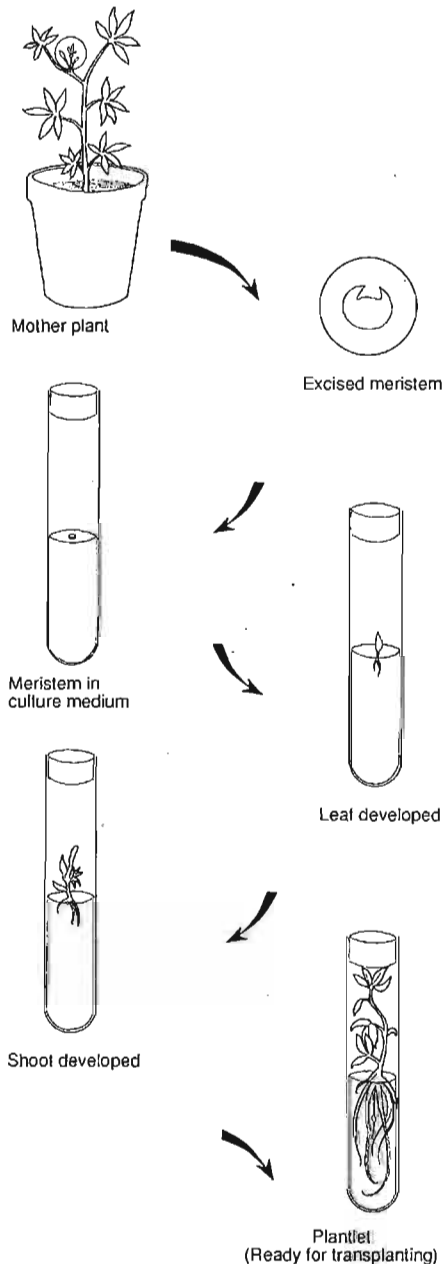

Figure 5.1
Process of meristem culture and plantlet development

1. Obtain woody cuttings from vigorously growing plants in the field. Wash cuttings thoroughly and disinfect with dilute chlorox solution by immersing the cuttings in the solution for 5 minutes.
2. Plant cuttings in sterile soil (chemically treated soil) in pots and place them in an isolated place, such as a greenhouse. Apply water to the soil; avoid watering the stem and leaf parts. It is recommended that insecticide be sprayed once a week to prevent infestation.
3. Transfer sprouted plants to a growth chamber, with a regulated day and night temperature of 37°C and with a 12-hour photoperiod, for 1 month.
4. Remove apical buds from the mother plant and transfer them to the laboratory in a container with a small quantity of distilled water. While both apical and lateral buds may be used for meristem culture, the successful rate of plantlets regenerated from a lateral bud is low compared with that of the apical bud.
5. Discard the distilled water and take the materials to the transfer cabinet. Disinfect buds with 70% ethanol for 3 to 5 minutes, followed by 10% sodium hypochlorite solution with a few drops of detergent for 20 minutes. The buds always float on the surface of the disinfectant so it is advisable to agitate the container once every few minutes to promote contact and penetration.
6. Discard the sodium hypochlorite solution and rinse the buds with three changes of sterile distilled water at 5-minute intervals to remove the disinfectant.
7. Remove the buds from the container using a pair of sterile forceps and transfer them to a sterile petri dish with sterile filter

paper or to the stage of a dissecting microscope which has been disinfected with 70% ethanol. The forceps are sterilized by dipping in 70% ethanol and flaming with a spirit lamp.

8. Place the petri dish under the dissecting microscope and, with the aid of a sterilized dissecting needle and scalpel, gradually remove the leaf primordia until the meristem is excised. Use the needle to transfer the meristem to the culture medium. Only a small part of the meristem is embedded in the medium, leaving a greater proportion above the surface of the medium.
9. Label the culture tube and/or container with the appropriate variety number and the date of culturing.
10. Incubate the cultures in a culture room with a temperature range of 25 to 28°C and a 12-hour photoperiod. Plantlets can be obtained after 8 to 10 weeks.

Procedure for multiplication

The procedure for multiplication is as follows (see Figure 5.2):

1. Obtain 1cm-long single node cuttings consisting of the bud and part of the petiole and stem from the green stem of a cassava plant.
2. Place the nodes in a container and disinfect with 70% ethanol for 5 minutes and 10% sodium hypochlorite with a few drops of detergent for 20 minutes; then rinse with three changes of sterile distilled water.
3. Remove the nodes from the container with sterile forceps and place them in a sterile petri dish with sterile filter paper to remove the excess water.
4. Place the nodes in the culture media and incubate in the culture room.

After 5 weeks, plantlets of four or five nodes are obtained and can be transplanted for hardening and eventually planted in the field, or packed for international distribution, or used for further multiplication. If the material is for further multiplication, it is subcultured by removing the plantlets from the culture tube, cutting them into several one- or two-node cuttings under the laminar flow cabinet, and transferring to fresh culture media. It is estimated that the multiplication ratio of cassava is 5 per 6 weeks.

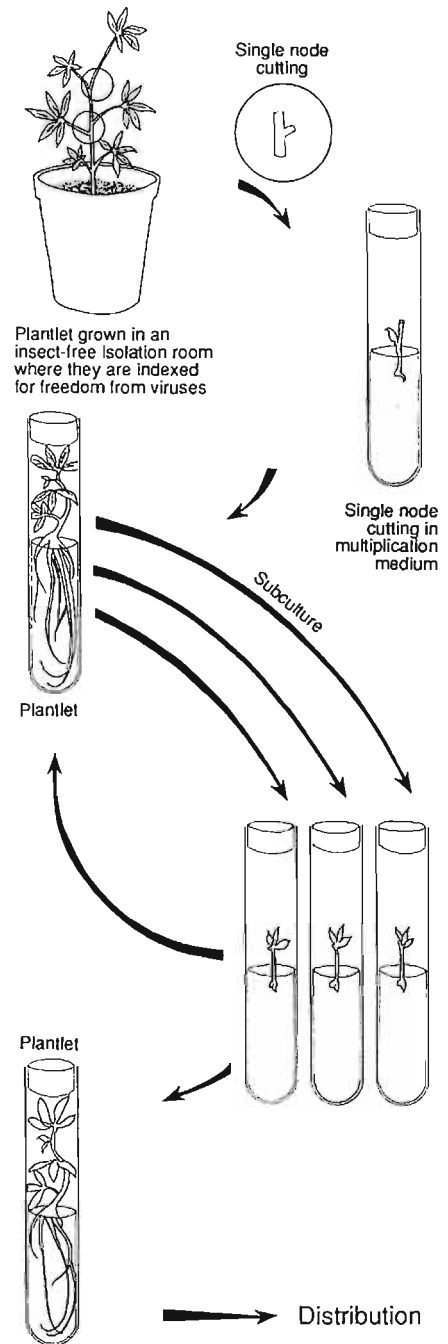

Figure 5.2
Rapid multiplication of disease-free cassava for distribution

Distribution and handling of tissue culture material

Distribution

Tissue culture materials are distributed as plantlets in test tubes after it has been ascertained that they are free from the diseases and insect pests of the original parent material. This is important because of the threat of many diseases and insects being spread by the use of vegetative propagating material. The test tubes are packed in a cardboard box together with a phytosanitary certificate, the import permit, a shipment form and a booklet explaining recommendations for handling tissue culture material. Transplanting media (such as jiffy peat pellets and vermiculite) and containers (such as jiffy pots) are packed and sent together with the tissue culture materials.

Handling during transportation

Transportation time should be as short as possible. A prolonged dark period (in the box) results in a low survival rate. If the journey takes longer than 4 days, exposure of the tube to light (not direct sunlight) during transit is required. Temperatures below 10°C and above 40°C are to be avoided, and the package should be kept in an upright position and protected from rain and direct sunlight.

Receipt of material

The tissue culture materials should be transplanted as soon as possible after receipt. If this is not possible, it is advisable to unpack the box and place the cultures under sufficient light (not direct sunlight), at temperatures between 20 and 30°C.

Plants in tissue culture are adapted to high relative humidity, almost 100% RH, and thus materials must be transplanted in an environment with high humidity. Transplanted materials probably have less epicuticular wax and their vascular development between root and shoot may not be complete. These two factors increase water loss and restrict water transport respectively.

A simple humidity chamber can be constructed using plywood, nails and covers made of transparent plastic sheets (*see* Figure 5.3). The humidity chamber is placed in shade and, if possible,



Figure 5.3
A humidity chamber

the temperature is kept at 25 to 35°C. The humidity inside the chamber can be maintained by spraying water to saturate the air.

Factors affecting the survival rate

Selection of culture and pre-treatment. Select cultures that are in good condition and use plantlets that are at least 3cm tall and have well-developed root systems. In cassava, certain practices have been used to strengthen the root system. These include exposing the cultures to higher light intensity, and loosening the culture caps to decrease the humidity gradually in the tube before transplanting.

Handling from tube to substratum. Transplanting the plants from tube to substratum requires great care. It is advisable to use blunt-end forceps (pointed forceps might damage the plant) to bring out the plant from the tube. Avoid breakage of the stem and especially of the root system.

Humidity control. Before transplanting the materials from the tube to the soil, a humidity chamber is made ready. The humidity in the chamber can be maintained by spraying water twice a day to saturate the air. The humidity is maintained at almost 100% RH for at least 3 days and then may be decreased gradually.

Temperature. The humidity chamber is placed in shade, preferably in a glasshouse. The temperature range is maintained at



Figure 5.4
Removing the plantlet from the tube



Figure 5.5
Handling the plantlet

25 to 35°C. If a glasshouse is not available, it is advisable to put the chamber under a tree or any other shade to avoid direct sunlight. The humidity chamber may also be placed on a laboratory bench but some artificial lighting would be required.

Watering. This is a very important factor in the survival of the plantlets. It is recommended that sufficient water is supplied each day. Avoid over-watering and flooding of the humidity chamber. After transplanting to the field, irrigation is necessary.

Transplanting cassava plantlets

The procedure for transplanting cassava plantlets is described below.

1. Prepare the humidity chamber and place under shade.
2. Soak the jiffy peat pellets in water; the peat pellet attains its final volume after soaking for about 3 hours.
3. Remove the net from the pellet and break the peat moss into fine pieces.
4. Mix two parts of the peat moss with one part of vermiculite.
5. Write a label to indicate variety number and date of transplanting.
6. Half fill the jiffy pot with vermiculite and peat moss mixture.
7. Remove the screw cap from the culture tube.
8. Hold the tube in the right hand and gently tap it with the left hand until the plantlet is half way out of the tube; if necessary, use blunt-end forceps to assist in the operation (see Figure 5.4).
9. When the plantlet is out of the tube, do not hold its stem (or the whole root system may break off from the stem). Figure 5.5 shows a plantlet just removed from a tube. Allow the plantlet to rest on the palm. If the medium remains attached to the root, place the palm with the plantlet in water and shake gently to remove the medium.
10. Hold the plantlet over the half-filled jiffy pot with the roots hanging inside the pot. Add the vermiculite and peat moss

mixture until the roots and the base of stem are covered. Press the mixture very gently to allow slight compaction. Insert the label in the jiffy pot.

11. Immediately after transplanting, place the jiffy pot in the humidity chamber.
12. Spray the humidity chamber with distilled water (if available), or cooled boiled tap water, to saturate the air.
13. Make sure that the chamber is closed properly.
14. During the first week of transplanting, spray the humidity chamber twice a day and water the plants once a day.
15. Water the plants with fungicide mixture (Benlate 5g/500ml) every other day to prevent fungal growth.
16. One week after transplanting, spray the humidity chamber only once a day and water the plants once a day.
17. Two weeks after transplanting, remove the plants from the humidity chamber, break the jiffy pots and transplant the plants into pots or plastic bags filled with ordinary or sterile soil.
18. Keep the plants in the pots or plastic bags under shade and water them once a day, until they are ready for transplanting in the field two weeks later.
19. After transplanting, irrigation is very important. Any drought occurring at this stage will destroy the plants.

UNIT 6

Agronomy

The agronomic practices associated with cassava are discussed in this unit under the headings of land preparation, planting, intercropping and harvesting.

Land preparation

Cassava production requires good soil preparation. Land preparation practices vary considerably, depending mainly on climate, soil type, vegetation, topography and degree of mechanization.

Where no mechanization is available and cassava is grown as the first crop after clearing forest, no land preparation is required other than the removal of the forest growth by cutting down small trees, shrubs and vines, and cutting off the branches of large trees to admit sunlight. Trees and bushes are piled and burned at the end of the dry season. When the first rains have softened the ground, the soil is loosened with a hoe, planting stick or sharp instrument so that the cassava stem cuttings can be planted easily.

The field may be prepared as mounds, ridges, flat-tilled or zero-tilled, depending upon soil type and drainage (*see* Figures 6.1, 6.2 and 6.3 *overleaf*). The size of the ridges or mounds and the placement of crops on them are influenced by drainage. Thus, water-loving crops such as rice may be placed between mounds or ridges in areas prone to water-logging, while cassava, maize and legumes may be planted on the sides and/or tops of the mounds or ridges.

Cassava cultivation on mounds is common in West Africa. The top soil is gathered into more or less conical heaps at various points in the field. Mounds that are specifically made for cassava range from 30 to 60cm high; on average, they are lower than those

prepared for yam but have much broader bases. This is perhaps a recognition of the fact that cassava tubers tend to spread more widely and penetrate less deeply than yam tubers. The space between mounds varies from 0.6 to 2m.



Figure 6.1
Cassava growing on mounds



Figure 6.2
Cassava growing on ridges

Where mechanization is available, many cassava growers plow and harrow the land to prepare a good seedbed. Plowing may be

to a depth of 25cm. The cassava is planted on the flat, on ridges or in furrows. For planting on the flat, the cuttings are inserted directly into the land after it has been harrowed. For planting on ridges or furrows, the land is ridged or furrowed after harrowing.



Figure 6.3
Cassava growing on the flat

Planting material

Cassava propagation material is vulnerable to adverse climatic conditions, as well as to pests and diseases. When exposed to the sun after cutting, it can lose viability quickly through dehydration; on the other hand, excessive moisture may cause bud sprouting.

Pathogens and pests are also common causes for poor sprouting after planting. Sprouting is better if stem cuttings harvested shortly before planting are used, rather than stored stem cuttings. Also, there are varietal differences in the sprouting vigor of stem cuttings, which are emphasized if the storage period is extended. (In this volume, 'stem cutting' is used instead of 'stake' to describe cassava planting material.)

For the best results in any cassava production enterprise, fresh stem cuttings from mature plants are ideal. However, if they are not available because of cold, prolonged drought or excess moisture, producers have to depend on reliable methods to preserve them. Cuttings stored in a dry, well-ventilated, shaded area where direct sunlight and dampness are avoided maintain their viability longer.

Quality of planting material

The quality of cassava stem cuttings depends on stem age, thickness, number of nodes per stem cutting (size) and health. Control of these factors is essential for the sprouting of vigorous plants capable of producing a good number of roots.

Age of the stem. In general, cuttings taken from the older, more mature parts of the stem give a better yield than those taken from the younger portions. Although cuttings from green stems will sprout, they are extremely susceptible to attack by soil-borne pathogens and sucking insects. Also, the immature herbaceous green stems cannot be stored for a long period because they have a high water content and tend to dehydrate rapidly.

When stem cuttings are taken from plants more than 18 months old, the stem is highly lignified and contains only small amounts of food reserves for the shoots. This adversely affects storage quality, root and shoot formation, and development, and the sprouting buds will have reduced viability. This is manifested in delayed sprouting and/or the production of shoots with little vigor.

It is recommended that planting material be taken from plants which are between 8 and 18 months old.

Thickness of cuttings. Although any part of the cassava stem can be used for propagating material in a commercial operation, thin stems which have poor nutrient reserves should not be used. This is because the shoots which develop from such stems tend to be weak and only a few, small tuberous roots are produced.

As a general rule, it is recommended that the thickness of the stems used for cuttings is not less than 1.5 times the diameter of the thickest part of the stem of the particular variety being used.

Number of nodes per cutting. The nodes on cuttings are important as origins of shoots and, if buried, of roots. A cassava plant may be obtained from a very small cutting with only one bud, but the possibilities of sprouting under field conditions are low, especially when soil moisture is limited. Cuttings with one to three nodes have low percentages of sprouting under field conditions because they are short and thus have lower food reserves and are more susceptible to pathogen attack and rapid dehydration. Cuttings with few buds are more likely to lose the viability of all their buds during propagation, transportation and planting. Long cuttings with more than 10 nodes theoretically have a better chance of conserving their viability because of the greater number of buds.

Long cuttings have been reported to give higher yields than short ones, presumably because the former had more buried nodes than the latter and thus produced more stems and leaves, which resulted in higher yields. However, when long cuttings are used, much more propagating material per unit of surface area is required.

The recommendation is that cuttings should have five to seven nodes and a minimum length of 20cm.

Health of cutting. Propagation material should be selected from disease-free plants. Generally, cassava stands from which planting material is to be obtained should be cut as close to planting time as possible. It is very important to avoid rough handling when cutting and transporting the selected stems or branches. The epidermis and buds of cuttings may be bruised or damaged by friction and machete wounds during preparation, transportation, storage and planting; each wound is a potential site of entry for micro-organisms that cause rot during storage or after planting.

The cut is made with a well-sharpened machete or circular saw. Fungicide treatment may be applied as a protectant when applying insecticide to control the insect pests found on the cuttings. This is not common practice among cassava farmers.

Planting

Cassava cuttings may be planted upright or at an angle in the soil, or horizontally beneath the soil, as follows:

- for planting in the vertical position, the cutting is usually inserted so that about two-thirds of its length is beneath the soil
- for planting at an angle, about two-thirds of the length of the cutting is beneath the soil, and the angle of the cutting to the soil surface varies from just slightly above horizontal to about 60°
- for planting horizontally, the cutting is inserted horizontally so that the entire cutting lies beneath the soil; depth of planting varies from 5 to 20cm but is usually about 10cm

The orientation of the cutting influences several growth characteristics of the plant. Cuttings planted vertically sprout and develop appreciable foliage slightly more rapidly than do angled and

horizontal plantings. Vertical plantings produce deeper tubers than angled plantings, while horizontal plantings produce the shallowest tubers. Tubers which are produced by vertical or angled plantings are more compactly arranged, and more difficult to harvest by pulling, than those which are produced by horizontal plantings.

Most mechanical planters in use today are designed to plant horizontally. The machine opens a furrow, the cutting is dropped horizontally, and soil is placed over the cutting.

Experience in many cassava-growing areas of different countries has shown that:

- in areas of medium to heavy soils with adequate rainfall (1000 to 2000mm/year) it does not matter whether cuttings are planted horizontally, vertically or at an angle because the moisture will be adequate for sprouting
- in areas of sandy soils or erratic rainfall, vertical planting is safest; cuttings from 20 to 30cm long will have at least 15 to 20cm in the soil and thus have better contact with available moisture

Time of planting

The aim in deciding time of planting is to ensure maximum utilization of the growing season. Cassava is planted as early as possible after the beginning of the rains or just before the main rains begin. Delayed planting leads to considerable reduction in yield. When planted early, the cutting sprouts, establishes well, and receives sufficient moisture for growth during the growing season; this enables the plant to withstand attack by diseases and pests later in the season. In Nigeria, the ideal time for planting cassava in most years is April/May.

Depth of planting

The depth of planting must be regulated according to the prevailing environmental conditions. Too much exposure of the cuttings in areas where soil moisture is below optimum can result in poor stands and, hence, low yields.

A good practical rule is that where there are dry sandy soils, cassava cuttings should be planted fairly deep, and where the soil

is moist and heavy, the planting depth should be fairly shallow. In the latter case, it should be remembered that deep planting will make harvesting difficult and increase production costs; however, deep planting is advisable in areas prone to termite attacks.

Plant population

Optimum plant density of cassava is largely dependent on edaphic and climatic factors, cassava varieties, soil fertility, cultural practices and the final utilization of the tubers.

In traditional systems, cassava is often grown as an intercrop among yams, maize, bananas and melons. The distance between cassava plants depends on how much space is taken up by the other crops, but in general the distances range from 1 to 4m.

Where cassava is grown as a monocrop, the rows and the spacing within the rows are both 80 to 100cm apart. Although there is no universal spacing recommendation which can be applied to all cassava-growing areas in Africa, a population of between 10 000 and 15 000 plants/ha generally gives a good crop of cassava.

Weed control

Like many other crops grown in the tropics, cassava is susceptible to early weed competition. Slow initial development of sprouts from cassava cuttings makes all cassava cultivars susceptible to weed interference during the first 3 to 4 months after planting.

Improved cuttings from cultivars with early branching habits are able to develop canopies which will reduce weed growth if:

- sprouts from cuttings are vigorous
- the crop is kept free from weed competition during the first 3 to 4 months after planting
- the plant population is not less than 10 000 plants/ha
- there is low pressure from diseases and pests
- environmental conditions and soil fertility status are favorable to cassava growth and development; when conditions are less than adequate or canopy fails to provide sufficient cover, weed problems could be as severe as in other arable crops.

Some of the major weeds affecting cassava production are grasses such as *Andropogon* spp., *Imperata cylindrica*, *Panicum maximum* and *Pennisetum* spp. and broadleaved weeds such as *Commelina* spp., *Chromolaena odorata*, *Mimosa invisa*, *Smilax kraussiana* and *Mucuna puriens*.

The problem with *I. cylindrica* is not limited to a direct reduction in yield. This weed also causes mechanical damage to the tubers which, when pierced, provide a point of entry for fungi and other pathogens; this leads to tuber rot and reduces the quality of produce.

Weed competition in cassava reduces canopy development, tuberization, tuber number and weight. Reduction in tuber yield varies from 40% in the early-branching cultivars to nearly 70% in the late- or non-branching cultivars.

There are four methods of controlling weeds in a cassava crop: cultural control (in Africa, generally hoe weeding); biological control; the application of various chemicals; and an integrated weed control.

Hoe weeding. This is effective when the farm size is small, and it is the most widely used method in cassava-producing areas because the crop is grown mainly by small farmers. The cultivated land is cleared from a bush fallow of more than 5 years' duration, and weeding is timely (three weedings at 3, 8 and 12 weeks after planting).

Biological control. Use of *in situ* mulch generated by growing a cover crop on stale ridges and seed beds is an innovative biological weed control method for cassava production.

Chemical control. Several herbicides have been identified for weed control for both sole cropping and multiple cropping. Herbicides that are recommended for pre-emergence weed control in cassava which has been planted from cuttings are chloramben (1 to 3kg/ha), diuron (1 to 3kg/ha), formulated mixtures of fluometuron and metolachlor (2 + 2kg/ha), metrobromuron and metolachlor (4kg/ha), fluometuron and pendimethalin (2 + 2kg/ha) and Primextra^m (2 to 3kg/ha).

Herbicides are most effective if applied to cassava before seedling weeds infest a newly planted field. Where cassava planting or weed control is delayed until seedling weeds become visible, the pre-emergence herbicide should be tank-mixed with a contact herbicide such as glufosinate-ammonium (Basta^m). In areas where

herbicides are available in small packs and the area planted to cassava is more than can efficiently be weeded by hand, herbicides have generally proved to be cost-effective. Injudicious use of herbicides is as unwise as advocating total avoidance of herbicide use without due consideration to the opportunity cost of using it safely.

Integrated weed control. This involves the judicious application of components of other weed control methods. Examples of integrated weed control are: combining one hand weeding with the use of an improved cultivar planted at optimum density; or combining the use of a low rate of a pre-emergence herbicide with late hand weeding.

Fertilizer use

One of the reasons for the widespread cultivation of cassava is the crop's ability to grow in soils that are too impoverished to support other staple crops. This is because the crop has an extensive root system and is able to utilize plant nutrients less accessible to other crops. It can produce a modest fresh tuber yield of 5 to 6 tons/ha on low-fertility soils that would not support other crops.

In traditional systems, cassava is usually grown without the application of fertilizers. Manures are used occasionally. However, to produce high yields the crop does require large supplies of nutrients, and this requirement can be met through the use of fertilizers.

Nutrient requirements

Although cassava can grow in a wide variety of soil conditions, to obtain optimal growth and good yields the crop requires friable light texture and well-drained soils which contain sufficient moisture and a balanced amount of plant nutrients. Under favorable soil and climatic conditions, fresh tuber yields of 40 to 60 tons/ha can be obtained.

Like all rapidly growing plants yielding carbohydrates, the cassava crop will rapidly impoverish the soil unless provision is made for replacement of the nutrients removed. The nutrient removal figures for cassava grown on different soils in Madagascar are given in Table 6.1, while Table 6.2 shows the equivalent amount of nutrients, expressed as fertilizers, that can be removed by cassava and yam (*see overleaf*).

Table 6.1

Nutrients removed by cassava grown on different types of soil in Madagascar

Soil type	Portion of plant	Nutrient removal in kg/ha					Starch content of roots (%)	Mean yield (t/ha)
		N	P	K	Ca	Mg		
Young, fertile, alluvial soils	root	153	17	185	25	6	29	42
	wood	100	11	65	17	23		
	Total	253	28	250	42	29		
Lateritic clay soils	root	178	20	91	26	3	23.5	26
	wood	107	16	31	30	9		
	Total	285	36	122	56	12		
Laterites, high in phosphate low in potash	root	138	28	24	47	6	16	8
	wood	108	23	12	42	30		
	Total	246	52	36	89	36		

Source: Jacob, A. and H. von Uexkull 1983 'Nutrition and Manuring of Tropical Crops'

Table 6.2

Equivalent amounts of nutrients (kg/ha) removed by cassava cultivars and yam species through crop harvest in Nigeria expressed as fertilizers

	Cassava cultivars		Yam species	
	53101	60506	<i>D. alata</i>	<i>D. rotundata</i> (var. Efurú)
Tuber dry matter yield (kg/ha)	7370	9350	9034	12133
Ammonium sulphate (21%N)	129	176	609	738
Single superphosphate (18% P ₂ O ₅)	89	115	215	232
Muriate of potash (60% K ₂ O)	142	228	323	352

Source: Obigbesan, G.O. 1977 'Nutritional Problems in Root Crops Production' in Proceedings of the First National Seminar on Root and Tuber Crops, Umudike, March, 1987

The figures show that cassava requires large quantities of nutrients and will respond to fertilizer treatment when grown on low-fertility soils. Like all starch or sugar-producing plants, cassava requires nitrogen, phosphate and large quantities of potash.

Nitrogen. Cassava requires a considerable amount of nitrogen. Nitrogen occurs in the soil in various forms. It is readily available in the form of $\text{NO}_3\text{-N}$ and can be leached into lower layers of the soil, particularly by rain. Nitrogen deficiency can be easily recognized by stunted growth of the plant; the leaves are narrow and pale green, with the discoloration starting at the leaf tips and margins, and they are shed prematurely.

Sufficient nitrogen is needed to develop a large bulk of foliage and thus an extensive assimilating area is a pre-requisite for good development of the tubers. However, excessive application of nitrogen, without the simultaneous application of phosphate and especially potash, may promote leaf and stem growth without a corresponding increase in tuber yield, or may result in lower tuber yield.

Phosphorus. This is important for the development of the root system. Although cassava has modest requirement for phosphorus, its response to phosphorus application under field conditions is low and varies greatly on different soils. Phosphorus deficiency can be recognized by stunted growth and a violet discoloration of the leaves.

Potassium. Although cassava removes large quantities of potassium from soils, an adequate supply of nitrogen and phosphorus seems to be more important in producing good tuber yield than a large supply of potassium.

The symptoms of potash deficiency begin with stunted growth; the leaf color is often dark and then gradually becomes paler. Dry, brown spots develop from the tips and margins of the leaves. In the final stage, necrosis occur on the margins of the leaves. Potash deficiency results not only in reduced yields and a lower starch content but also has an unfavorable effect on root quality.

Application. A satisfactory balance between nitrogen and potassium in the fertilizer mixture is important in fertilizing cassava. The interaction of the various nutrients applied needs to be considered. In timing the application of nitrogen, it must be borne in mind that nitrogen fertilizers are easily leached out by rain, and thus it may be more expedient to postpone the application until the plants are well developed.

Intercropping

Multiple cropping (growing two or more crop species on the same field in the same year) is almost the rule in tropical agricultural systems; cassava is rarely grown as a sole crop except on a few large-scale mechanized farms.

Multiple cropping includes intercropping (growing two or more crop species simultaneously on the same piece of land) and sequential intercropping (growing two or more crop species, one after the other, on the same piece of land in one year).

Intercropping is the most dominant multiple cropping system in most parts of the humid tropics, especially under rainfed conditions. It is associated with shifting cultivation or rotational bush fallow in which farm land is abandoned after 2 to 3 years of cropping so that it may revert to natural fallow, a method used to maintain soil fertility.

Intercropping may be practised as:

- mixed intercropping (growing two or more crop species in an irregular arrangement)
- row intercropping (growing two or more crop species in a well-defined row arrangement)
- strip intercropping (growing two or more crop species in strips wide enough to allow independent cultivation and yet narrow enough to induce crop interactions)
- relay intercropping (planting one or more crop species within an established crop so that the final stage of the first crop coincides with the initial development of the other crop or crops)

Of these various types of intercropping, the most common one practised in the cassava-growing areas of the humid tropics is mixed intercropping.

Because the humid tropics are characterized by high rainfall (that is, where rainfall exceeds potential evapotranspiration for 5 or more months in the year) and thick vegetation cover, soil management in traditional agriculture is such that the topsoil is covered by the canopies of a multispecific crop mixture. In such a system, opening up new farm land is done with simple tools, usually a hoe, which disturb only the topsoil. Some large trees and palm trees are

left, but the rest of the cleared land is burnt, leaving ash mulch on the soil. Soil erosion and pest and disease incidence is reduced by growing a mixture of crops with varying canopy configurations. Yields are maintained at a fairly stable but low level, while the soil fertility status is maintained by fallowing. Farmers tend to adapt to changes in soil fertility by planting those crops which require most nutrients first (such crops include maize, yam and plantains); tuber and legume crops, which have a lower nutrient requirement, are planted later.

The advantages of intercropping are:

- higher gross returns per unit area of land
- yield stability
- satisfaction of family dietary requirements
- control of pests, diseases, weeds and erosion
- more even distribution of labor

The disadvantages of intercropping include:

- difficulty in mechanizing planting and harvesting operations
- difficulty in applying fertilizers and pesticides in mixed cultures
- difficulty in managing experiments (these are usually more complex in intercropping than in sole cropping)

Cassava is usually intercropped with vegetables, plantation crops, yam, sweet potato, melon, maize, rice and legumes. The intercropping pattern depends on the environmental conditions and the food preferences of the region.

Cassava-based intercropping systems can be divided into simple mixtures (which consist of only two crop species) and complex mixtures (which consist of three, four or more crop species). As a long-duration crop (9 to 18 months), cassava is well suited to intercropping with short-duration crops such as maize, cowpea, groundnut, melon, okra, rice, cocoyam and several leafy vegetables.

In simple mixtures, arable crops are usually selected on the basis of differences in growth habit and time of maturity. For example, cassava (slow initial growth, 9 to 18 months to maturity) is often grown with maize (rapid growth, about 100 to 120 days to maturity),

cowpea, melon (rapid growth, 70 to 80 days to maturity), groundnut (rapid growth, 120 days to maturity) or okra (harvested over a period of 50 to 100 days).

Higher returns and a greater number of calories have been obtained from the following complex mixtures: cassava/maize/melon; cassava/maize/okra/melon; cassava/maize/okra/cowpea; and yam/maize/cowpea.

These complex mixtures are also known to suppress infestation by weeds, reduce soil temperature, retain higher soil moisture up to a depth of about 20cm and produce higher organic matter than in the case of sole cropping or simple mixture intercropping. Nutrient loss resulting from erosion under complex mixtures is less than in sole cropping.

Harvesting and yields

The exact time for harvesting a cassava crop depends on several factors — the cultivar, the rainfall, soil conditions and the temperature regime.

It is best to harvest cassava at a time when the tubers are old enough to have accumulated a sufficient amount of starch but not so old as to have become excessively woody or fibrous. Late-maturing cassava cultivars are ready for harvesting 12 months after planting, while some early-maturing cultivars are ready at 7 months.

Table 6.3

Effect of time of harvest on yield of different varieties (kg/plot)						
Variety	Time of harvest (months)					Mean (t/ha)
	12	15	18	21	24	
60447	312	449	482	455	430	17.7
53101	343	401	494	452	421	17.2
37065	248	302	396	284	304	13.1
44086	202	309	267	210	265	9.6
Mean (t/ha)	11.5	15.5	16.7	14.8	13.2	14.4
LSD (P = 0.05)	13.4kg/plot					

Source: Hahn et al. 1979 'Cassava Improvement in Africa' Field Crops Research 2:193-226

Studies have shown that several cassava cultivars attain optimum fresh weight at about 18 months after planting. This corresponds to the time of highest starch accumulation. The effect of the time of harvesting on yield and on the percentage of starch for four cassava varieties is shown in Tables 6.3 and 6.4 respectively.

In practice, cassava plots are seldom harvested all at once or all at the recommended time of harvesting. The main reason for this is that the cassava tuber is highly perishable and, once it has been harvested, cannot be kept in good condition for more than 2 days after harvesting. Therefore, farmers harvest the amount of tubers that they require for immediate use, leaving the remaining tubers unharvested until needed.

Table 6.4

Effect of time of harvest on percentage of starch						
Variety	Time of harvest (months)					Mean
	12	15	18	21	24	
60447	16.0	18.2	23.2	16.1	15.1	17.1
53101	19.4	24.2	26.6	15.0	19.6	21.0
37065	15.5	18.8	18.7	12.2	17.5	16.5
44086	17.8	21.3	22.0	19.0	16.2	19.3
Mean	17.2	20.6	22.6	15.6	17.1	18.6
LSD (P = 0.05)	5.2 (variety)					

Source: Hahn et al. 1979 'Cassava Improvement in Africa' *Field Crops Research* 2:193-226

In traditional agriculture, hand-harvesting, an extremely laborious process, is the rule. Limited mechanical harvesting of cassava has been reported but no satisfactory cassava harvester has yet been developed.

In hand-harvesting, a machete is used to cut off the stem a few centimeters above the ground. The soil around the tuber is then loosened, using the machete, and the stub of the stem is pulled to lift out the tuber.

Whatever harvesting method is used, the task is easier when the soil is wet. It also tends to be easier if planting is done on ridges or

beds and in loose or sandy soils, rather than on flat ground and in clay or heavy soils.

Yield, resistance to major pests and diseases, HCN content and other characteristics of some improved IITA cassava varieties are presented in Table 6.5.

Table 6.5

Main characteristics of some improved IITA cassava varieties¹

Variety	Av. yield t/ha	Percent dry matter	Dry yield t/ha	HCN mg/100g	Resistance to ²				Garification	Gari ³ quality
					CMV	CBB	CGM	CM		
TMS 50207	23.2	28.0	6.5	6.6	2.0	1.7	3.3	3.5	17.0	G
TMS 4(2)1425	21.4	34.4	7.4	3.3	1.8	1.8	2.3	2.8	22.5	VG
TMS 50395	20.4	27.5	5.6	10.7	1.8	1.7	3.0	3.5	18.5	G
TMS 30337	20.4	28.0	5.7	6.5	2.3	1.7	3.8	3.0	15.0	M
TMS 30572	20.2	31.5	6.3	4.7	1.9	1.7	3.3	3.5	20.0	VG
TMS 63397	19.5	33.6	6.5	6.2	1.6	1.4	3.0	2.8	18.0	G
TMS 30211	18.1	29.5	5.3	3.5	1.8	1.6	3.8	3.2	16.5	M
TMS 40081	17.9	31.0	5.5	4.4	1.7	1.4	4.0	3.0	16.5	G
TMS 30555	15.4	31.5	4.8	3.7	1.9	1.8	3.3	3.8	21.0	G
TMS 4(2)0267	15.0	34.7	5.2	5.0	2.2	1.6	2.5	2.3	20.0	M
TMS 30001	14.1	31.2	4.4	4.8	1.4	1.8	4.0	3.5	18.5	VG
TMS 42025	13.2	35.8	4.7	7.0	2.0	1.6	2.3	2.3	21.5	VG
60506	12.4	27.4	3.4	5.7	2.7	2.6	4.0	3.0	17.0	G
TMS 60142	11.1	35.4	3.9	3.7	2.2	2.2	2.4	2.0	21.5	G
LSD (5%)	2.6	0.14			0.42	0.42				
SE (±)	0.95	0.39			0.12	0.12				

Notes:

¹ Average of four locations in Nigeria, 1983-1985

² See Unit 11 for explanation of the scoring system

³ VG = very good, G = good, M = moderate, and P = poor

UNIT 7

Crop Protection

Crop protection against pests and diseases is a crucial element of cassava production. More than 50 cassava diseases induced by fungal, bacterial, mycoplasmal, phytonomonal and viral agents have been reported. These diseases can affect plant establishment and vigor, inhibit photosynthetic efficiency and cause preharvest or postharvest deterioration. Severe infestation often leads to a considerable yield loss and thus it is important to undertake control efforts as early as practicable.

Cassava pests represent a wide range of arthropods; most of them are minor pests but a few, including mites and whiteflies, may be classified as major pests. Insects can cause damage to cassava by reducing photosynthetic area, which results in yield reductions; by attacking stems, which weakens the plant and inhibits nutrient transport; and by attacking planting material, which reduces sprouting. Those mites and insects that attack the stem also lessen the quality and quantity of planting material taken from these plants, thus affecting production. Soil-borne insects attack cuttings, causing wounds or boring holes through which soil-borne pathogens can enter.

Diseases

African cassava mosaic virus and cassava bacterial blight

The use of disease-resistant, improved varieties is recommended as a method for controlling ACMV and CBB. A considerable amount of work was put into cassava breeding before varieties which were resistant to both diseases were obtained. Resistance to ACMV and CBB is highly correlated, and thus when a cultivar is bred for resistance to ACMV, resistance to CBB is likely to be achieved.

IITA uses recurrent selection to improve resistance to ACMV and CBB, together with other agronomic characteristics, while maintaining a large genetic variation. Resistance alone was improved in one cycle of 2 years; to combine resistance with high yield took 4 to 5 years.

Cercospora leaf spot

No control measures are required with *Cercospora* leaf spot because the disease sets in after the plant has matured and tuberized. It is essentially a disease of older plants and no yield loss has yet been traced to it.

Cassava anthracnose disease

Little work has been undertaken on controlling CAD because the incidence and severity of this disease have not been correlated to yield loss. However, screening studies are being carried out to identify CAD-resistant varieties which can be recommended to farmers.

Tuber rot

It has been found that tuber rot is prevalent in heavy, poorly drained soils. For this reason, friable, well-drained soils are recommended for cultivating cassava.

Pests

Vertebrate pests

In areas where African bushfowl and cane rat populations are high, various methods of reducing these populations are practised, including hunting, trapping, snaring and poisoning. Because most people in such areas eat bushfowl and cane rats, poisoning is not recommended.

Nematodes

Nematodes are usually controlled by the application of nematicides, such as Nemagon and ethylene dibromide. In developing countries, these chemicals are not usually available; when they

are available, they are expensive. An effective alternative is crop rotation. Good weed control prevents the growth of alternate hosts when cassava has been harvested from the field. The use of nematode-trapping crops such as *Crotalaria* spp. during the fallow year is advocated as a control method. Soil organic matter amendment using cocoa pod husks and cassava peels has been found to be successful in reducing the parasitic nematode population in the soil.

Mites

Cassava green mite needs to be controlled because it damages cassava leaves and reduces tuber yield. Biological control using natural enemies, as well as the use of pubescence in young leaves and shoots, is being investigated.

Insects

Usually, there is no need to control insect pests of cassava, apart from cassava mealybug and the variegated grasshopper.

CM represents a classical example of an insect that can be biologically controlled by using other insects and natural enemies (see 'Biological Control' below). The parasitic wasp, *Epidinocarsis lopezi*, is an exotic natural enemy at present being released in Africa and has been found to be effective in controlling CM. An indigenous natural enemy, *Hyperaspis pumila*, plays a secondary role in biological control.

Pubescent plants prevent the establishment of the mealybug and are being investigated in cassava breeding work.

Early planting is recommended to allow the cassava plant a good growth before the dry season when plants are invaded. Before planting, cuttings may be treated with dimethoate solution to kill all insects and mites to prevent their establishment in a newly planted field.

In the case of the variegated grasshopper, the easiest and most economical protection method is to control the freshly hatched nymphs; however, the success of this method depends upon the extent of cooperation by neighboring farmers. Once freshly hatched nymphs are detected, they should be treated with insecticides (such as Rogor and Gammalin 20) or poisonous bait should be laid.

Biological control

Biological control is a pest management procedure which relies on and augments the activity of natural enemies of a pest organism. It has been used for hundreds of years. The first modern example, which was later repeated in Africa, was the spectacular control in the USA of the cottony cushion scale, *Icerya purchasi*, by the ladybeetle, *Rodolia cardinalis*, introduced from Australia in 1888.

Modern biological control relies mostly on specific insect natural enemies, predacious mites and microbial agents. Among the beneficial arthropods are the predators (which feed on many host individuals) and the parasitoids (which need only one host individual for their development).

Biological control strategies establish a new ecological balance by using biological agents. Typically, a pest problem arises when the natural balance is disrupted, as is the case when a pest invades a new geographical area which is devoid of its natural enemies. An undesirable pest level is attained because the natural balance that usually exists in the pest's area of origin has been upset.

Three types of biological control can be distinguished:

- The action of indigenous predators and parasitoids (fortunately, in the African environment, beneficials are often still relatively undisturbed)
2. Periodic manipulation, including inundative releases of natural enemies (except for the application of microbial pathogens, this approach is generally too sophisticated and costly for African conditions)
3. Classical biological control, which is the introduction of natural enemies for permanent establishment (often, the pest concerned has been accidentally introduced from abroad; but some deliberate introductions of natural enemies are known to have been successful against indigenous pests)

Classical biological control is the attempt to restore an ecological balance by introducing the natural enemies that keep the pest in check in its native habitat. Such a control strategy is particularly useful in developing countries because it permits farmers to benefit from a relatively quick, permanent and ecologically sound technology without the extra capital expenditures or specialized training required for most of the other control practices.

Major cassava pests for biological control

The cassava mealybug, *Phenacoccus manihoti*, Mat.-Ferr. (Hom.: Pseudococcidae), and the cassava green mite, *Mononychellus tanajoa*, Bondar (Acari: Tetranychidae), were introduced into Africa in the early 1970s and have successfully spread through most of the cassava belt. Yield losses from the activities of these pests are as high as 80%.

The IITA Biological Control Program, originally established as the Africa-wide Biological Control Program of Cassava Pests (ABCP), has two major objectives: to reduce yield losses by re-establishing the natural control found in the pests' area of origin; and to create an African biological control capacity by training specialists and helping to establish national biological control programs.

Cassava mealybug. First discovered in Africa in Congo/Zaire in 1973, CM is a parthenogenetic species which, under tropical conditions, develops from egg to adult in 27 days. The adults live for about 20 days, during which time they produce up to 400 eggs, most of them in the first 10 days.

CM attacks the growing points of the plant first, producing a stunted, bunched effect in the terminal shoots. A toxin present in its salivary juice contributes to this leaf distortion. Further symptoms are short internodes, little new leaf growth, and curling of leaves. Very young plants may be killed, and any attacked plant is significantly weakened (see Figure 7.1).

Cassava green mite. CGM was first observed in Africa in 1971, attacking cassava fields in Uganda. It was introduced from South America.

CGM is principally a dry-season pest but it may be found throughout the year on new shoots and on the undersurface of young leaves. During their lifetime of 3 to 4 weeks, adult females produce between 20 and 90 eggs each, depending on the quality of the available foliage; the development time from egg to adult is about 14 days.

The mite feeds by inserting a pair of needle-like mouthparts into individual plant cells and sucking out the fluid content. The damage which is caused to cassava plants by CGM is similar in appearance to the symptoms of ACMV attack. Leaf damage varies from a few chlorotic spots to complete chlorosis, depending on the extent of CGM feeding activity. Leaves which have been heavily attacked are stunted in growth and become deformed as they



Figure 7.1
Cassava plant damaged by cassava mealybug

mature (see Figure 7.2). The leaves may become mottled and eventually dry out, die and abscise.

CGM feeding leads to a reduction of dry matter in the leaves, stems and tubers of plants which have been heavily infested. Depending on the age of the plant and the time of the season, dry matter reductions of up to 45% have been reported for improved varieties. Damage caused by CGM also exacerbates weed problems and affects the quality and quantity of cutting material available for replanting.

The principal way of dispersing CGM is to collect and move the planting material from one area to another. It may also be dispersed aerially.



Figure 7.2
Cassava plant damaged by cassava green mite

Control measures

A classical biological control program consists of four well-defined stages (see Figure 7.3).

1. *Foreign exploration for natural enemies.* The first step in planned biological control against a pest organism, which is supposed to have been introduced accidentally, is to locate its area of origin, where parasitoids and predators have co-evolved with it over a long period. Exploration in this area usually provides numerous species of natural enemies but often in very limited numbers.

2. *Quarantine processing and rearing of identified natural enemies.* The collected species are identified in a quarantine station — usually the quarantine facilities at the Commonwealth Institute of Biological Control in London, because tropical organisms cannot survive in the European environment. The species are reared as safely as possible to prevent escape, their biology is studied and they are checked to ensure that they are disease-free. Their host specificity is evaluated and hyperparasitoids (parasitoids of parasitoids) are excluded. If these processes are carried out properly, biological control is a completely safe procedure. No cases are known, or are expected to be found, of parasitoids and predators switching to plant food once their insect host has been reduced; they simply survive at the very low population levels at which their host survives.

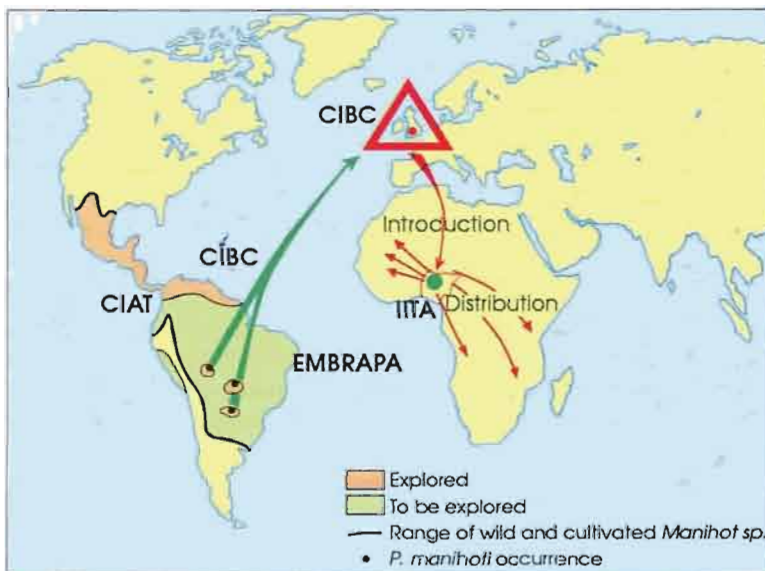

Figure 7.3
Stages in a biological control program

3. *Mass-rearing and introduction.* From quarantine, the selected beneficial organisms are mass-reared in a laboratory, then released into the field under the best possible conditions. Establishment often occurs with releases of less than 200 individuals; in general, however, larger releases are favored to allow ample genetic recombination in the new conditions.
4. *Impact evaluation.* The released populations are then monitored. Ideally, the impact is measured and related to crop loss,

but, in practice, proving the impact of the released organisms is often difficult because nearby control fields cannot be kept uninvaded by the established beneficial. Experimental exclusion of parasitoids and predators by using insecticides, sleeves or other measures sometimes proves the efficiency of the control agent, and studies on density-dependent behavior, life tables and mathematical models are conducted to support this proof (examples of this procedure are given below).

Procedure for cassava green mite

Identification and importation of natural enemies. Mites of the family Phytoseiidae are used as the primary agents against CGM. Their ability to control spider mites in many agro-ecosystems in temperate climates is well established, and their potential as biological agents is well documented.

Exploration for natural enemies of CGM in the Neotropics is undertaken by the Centro Internacional de Agricultura Tropical (CIAT) and the Empresa Brasileira de Pesquisa Agropecuária (EMBRAPA). These institutions explore areas that correspond ecologically to areas in Africa where the mite is a severe problem. As species are identified during exploration, their biological characteristics are noted and added to a database for selection purposes.

Other work which is being carried out in the field of the biological control of cassava includes: the international quarantine services at the University of Amsterdam, Netherlands; taxonomy of tetranychids at the University of São Paulo, Brazil; taxonomy of phytoseiids by EMBRAPA in Petrolina, Brazil; regional liaison assistance from the CAB International Institute of Biological Control in Nairobi, Kenya; simulation modeling of the cassava ecosystem, including CGM, at the University of California, Berkeley, USA, and the Federal Institute of Technology (ETH) in Zurich, Switzerland; and artificial diets for transporting natural enemies of CGM, a survey of entomopathogens of CGM, and the biotaxonomy of CGM at the International Center for Insect Physiology and Ecology (ICIPE).

Selection of release sites. Potential release fields are identified and surveyed for CGM and associated natural enemies prior to making any releases. In the fields which are chosen for releases, the cassava plants are vigorous enough to support increasing CGM populations during the dry season but also young enough not to be harvested during the following wet season.

Packing and transport. Most phytoseiids packaged for shipment are a mixture of age classes. The egg stage travels without problems as long as the humidity is above 50% RH. However, in the active stages special attention is required. If badly packed, actives are susceptible to rapid dehydration. Starvation causes cannibalism.

Phytoseiid shipments are packed in containers or vials with agar as a source of confined moisture and some type of inert, non-hygroscopic material which is folded to increase the surface area. No plant material or live host material is included. These containers are placed inside a coolbox where the temperature is maintained at about 15°C. The package is kept closed while being transported. Exposure to X-rays or other forms of radiation (for example, security screening devices at airports) is avoided.

Handling. Upon the arrival of a shipment in the country where the release is to be made, about 300 phytoseiids are added to 10 well-infested leaves and placed in individual paper bags. The bags are closed by folding over the top a couple of times and securing the fold with a staple, paper clip or straight pin. Care is taken not to crush the paper bags or expose them to direct sunlight while the predators are being transported. The predators feed and reproduce on the leaves for about 5 days. The bags are stored in a cool place.

Releases. Once appropriate release fields have been identified, individual plants are selected to receive the released material and are marked with some type of flag. Each phytoseiid species is released in a separate field. Predators are released by placing individual infested leaves, complete with predators and their eggs, on the young, fully developed leaves of the cassava plant.

Taking into account the mortality suffered by the phytoseiids in transit and the number of CGM-infested leaves provided as food, infested leaves are distributed to provide a density of 10 to 50 actives per cassava plant in a defined part of the release plot. The best times for releasing natural enemies are at the beginning of the dry season and just after the first rains of the long wet season, when CGM populations rapidly increase to high levels.

Monitoring. After exotic natural enemies have been released, routine follow-up monitoring is carried out in order to determine whether the species has become established. Its dispersal and its impact on the target species is measured. CGM populations in the release and control fields are monitored, using approved census procedures. Natural enemies in the release fields are sampled,

and the leaves and green stems from three or four plants of the most abundant weed species are examined for tetranychids and associated natural enemies. Any specimens found are collected in the field.

This follow-up activity is done twice a month during peak periods of CGM activity, once a month during the transition periods between seasons, and bi-monthly during the wet season. Specimens from weeds are collected on every alternate trip to these field sites.

Procedure for cassava mealybug

Identification and importation of natural enemies. The wasp *Epidinocarsis lopezi* (De Santis) (Hymenoptera, Encyrtidae), which parasitizes CM, has been established successfully in many cassava-growing areas in Africa where it has been released by IITA. A natural enemy is considered established when it has survived a full rainy season — the period of low CM population — and has been located again 12 months after release. *E. lopezi* has spread rapidly to other cassava-growing areas and is established in 22 countries, over a total area of 1.5 million km². It has caused considerable reductions in CM populations, making it a successful biological control agent against this pest.

The search for exotic natural enemies of CM began in central and northern South America because cassava, the only natural host of CM in Africa, was introduced from South America. In 1981, CM was finally discovered in Paraguay by CIAT. Several predators and parasitoids were collected and quarantined by the Commonwealth Institute of Biological Control in London. After approval by the Inter-African Phytosanitary Council and the Nigerian plant quarantine authority, they were then sent to IITA.

Further explorations in Paraguay, Brazil and Bolivia led to the collection of *E. lopezi*. After collection and importation to IITA, *E. lopezi* was reared on CM on potted cassava plants.

Selection of release sites. Before the release of *E. lopezi* at any site, an extensive survey is carried out in order to:

- investigate the distribution and abundance of the pest and select release sites based on infestation levels
- estimate the population of the pest, thereby providing a basis for impact assessment of the natural enemies

- determine the species composition of infested cassava fields, a procedure which is also relevant to the impact assessment

This survey is usually conducted during the dry season when CM populations are at their highest. A particular area is sampled once (or, at most, two or three times) during this period. The location of sampling points is determined to a large extent by accessibility. Where there are suitable roads or trails, the selection of sampling points is more often systematic (at regular intervals of 10km, for example) than random. However, in order to obtain population estimates for future impact studies, a combination of systematic and random sampling is involved. Collection and conservation of infested shoots provide data on species composition. The sampling unit is the terminal shoot because this is where CM is usually concentrated. Infestation levels are determined as a basis for site selection.

Releases. Most releases are made in the second half of the dry season into fields with high CM populations. All releases are conducted in collaboration with local agronomists or entomologists. Ground releases are made by pouring the insects directly onto infested plants. In some areas, aerial releases are also undertaken.

Monitoring. The efficiency of a released natural enemy depends on its searching capacity and rate of dispersal; these factors indicate to a large extent whether the natural enemy will be established or not. The first stage in the impact assessment therefore involves determining the spread and establishment of the released natural enemy. Starting from the release site, systematic samples are taken from various points over a large area. This may be done two or three times during the dry season. To obtain additional information on the populations of both the pest and the natural enemy, a field which is selected systematically is randomly sampled.

Sampling consists of randomly selecting 50 plants and carefully breaking off the upper 10cm of the tips of the shoots. These are put inside paper bags to prevent any escape by natural enemies, and the bags are then sealed and taken to the laboratory. Here, the tips are dissected, and living CM and dead, hardened and parasitized CM ('mummies'), as well as natural enemies, are counted. Mummies are kept in gelatine capsules in the laboratory for parasitoid emergence.

The living CM are reared on cassava leaves or, preferably, on detached fleshy leaves of water leaf, *Talinum triangulare* (Jacq.),

an alternate host of CM which remains fresh for a longer period than cassava in petri dishes. The rearing continues for 3 to 4 weeks. Daily observations are made on emergence of parasitoids, which are immediately removed to keep them from stinging the remaining CM. Coccinellid and other larvae are also reared to adults for proper identification. Monitoring is done every 2 weeks.

Parasitization rates are calculated by relating the number of emerged parasitoids from mummies and living CM (second to fourth instars) to the total number of second to fourth stage CM (*E. lopezi* does not reproduce in first instar CM).

Integrated disease and pest management

A sound integrated control program for pests and diseases is essential in any program aimed at yield improvement and stability. The program should involve not only biological control practices, but also good cultural practices and ecologically adapted resistant varieties. The use of chemical control should be considered only when other control measures are ineffective. If an outbreak does require pesticide applications, it should be done selectively, bearing in mind the possible lethal effects on beneficial agents.

Cultural practices

There are many cultural practices that contribute to pest and disease control. Uniform practices cannot be recommended for all cassava-growing areas; they must be adapted to the specific characteristics of each ecosystem. In general terms, however, the following practices are likely to reduce pest and disease stress:

- proper soil preparation
- the use of clean, high-quality planting material
- good weed control
- removal and destruction of infected plant material/debris
- crop rotation
- intercropping cassava with other crops
- well-planned spacing of plants

- proper fertilization
- strict quarantine regulations

Varietal resistance

Yield stability is related to climatic, edaphic, pathological and entomological stresses, and to the genetic capacity of clones to tolerate these stresses; these stresses are known as negative productive factors (NPFs). The cassava/ecosystem interaction is considerable because, for a long time, cassava clones have been selected in localized areas and perpetuated vegetatively.

A well-adapted clone with tolerance to a given ecosystem could be severely affected by the NPFs of another ecosystem. Thus, in each ecosystem regional clones or clones from similar ecosystems should take preference over those introduced from ecosystems with different sets of NPFs. Introductions are made specifically to improve the gene pool existing in an ecosystem (regional clones).

Clonal evaluation should be based on the following criteria:

- a satisfactory yield of fresh tubers, starch and foliage, according to the utilization of the plant
- a good production of high-quality planting material
- highly acceptable tuber quality, according to regional socio-economic requirements

Clones selected according to these criteria would be the most acceptable to farmers and therefore be the most stable over time. Clonal evaluation in each ecosystem should be directed at identifying genotypes with the widest type of resistance to the NPFs existing in it. This evaluation should be performed in areas of a particular ecosystem where NPFs are most severe and most frequent. This should not eliminate or underrate evaluations directed at identifying tolerance to specific important biotic problems; such evaluations could be needed to improve clones which have wide resistance but are deficient in certain required characteristics.

Varietal resistance obviously enhances the impact of biological control because economic damage occurs only at higher population levels, facilitating the increase of beneficial biotics and reducing or eliminating the need for pesticides.

Part III

Postharvest technology



UNIT 8

Storage of Fresh Cassava

Cassava tubers are extremely perishable. They can be kept in the ground prior to harvesting for up to about 2 years, but once they have been harvested they begin to deteriorate within 40-48 hours. The deterioration is caused by physiological changes and, subsequently, by rot and decay. Mechanical damage during the harvesting and handling stages also renders the crop unsuited to long-term storage.

Deterioration of cassava has an adverse effect on the processed product, and thus the crop must be stored properly. Traditional and modern methods of storage have been devised to combat post-harvest losses.

Traditional storage methods

In most areas where cassava is grown under subsistence farming conditions, the problem of storage is overcome by leaving the mature cassava crop in the ground until needed. The main disadvantages of this method are that:

- large areas of land are used as a storehouse for the already mature crop and therefore cannot be used for further cropping; this decreases the economic output of the land and increases pressure on the land (there is already a considerable amount of pressure on the land in many countries in Africa because of high population growth rates)
- susceptibility to loss is increased because the tubers are vulnerable to attack by rodents, insects and nematodes
- tubers become more fibrous, lignification occurs, and consequently the crop's starch content and its suitability for many food preparations decline

Other traditional methods, based on the principle of preventing moisture loss from the tubers, include:

- storing harvested tubers in pits (this involves burying them in pits lined with straw or some other vegetative material)
- piling them into heaps and watering them daily to keep them fresh
- coating them with a paste of mud
- storing them under water

These methods prolong the shelf life of cassava by only a few days and are not widely used.

Improved storage methods

Among the improved storage methods for fresh cassava are those based on techniques involving freezing, gamma irradiation, control of storage environment (relative humidity and temperature) and waxing. However, none of these techniques has been sufficiently tested. Three improved storage methods which have undergone sufficient testing, including field testing, involve:

- dipping fresh tubers in fungicide and packing them in polyethylene bags
- storing them in specially prepared trenches
- storing them in moist sawdust

Although these three methods are not yet widely used, they are useful for small- and medium-scale cassava production.

Storage in polyethylene bags

This method appears to be the simplest way of storing tubers. If properly conducted, it ensures a shelf-life of 2 weeks or more.

The method is based on the principle of 'curing' — the capacity of the tuber to form a new layer of cells over damaged tissues. Freshly harvested roots are treated with 0.4% solution of Mertect, a thiabendazole-based fungicide. They are then packed in polyethylene bags and sealed. Inside the bags, the tubers create the

necessary temperature/humidity environment (temperature should range between 30 and 40°C and RH should exceed 80%). The fungicide treatment prevents the growth of micro-organisms in the humid environment.

Storage in trenches

This low-cost method, developed by the Nigerian Stored Products Research Institute, keeps cassava fresh for at least 6 to 8 weeks and can be implemented easily by farmers and processors.

A trench is dug in the ground at a site which has a low water table, thus protecting the tubers from seepage of underground water. The trench should be 2m long, 1.5m wide and 1m deep. Depending on the size of the tubers, a trench of this size can store from 0.5 to 0.7 tons of cassava.

A shed made of wood and iron, or bamboo, with a thatched roof, is constructed over the trench. It is economical to make several trenches under the same shed (see Figure 8.1).

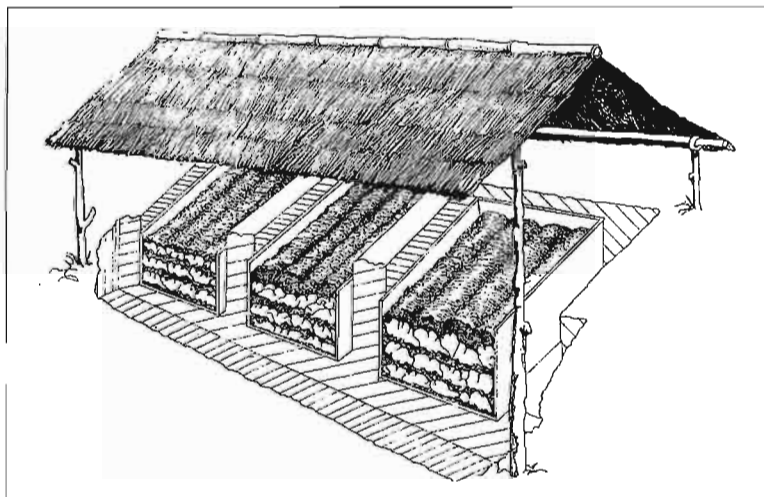

Figure 8.1
Fully filled trenches under a protective shed

Two layers of palm branches or raffia leaves are laid on the bottom of the trench. One or two layers of freshly harvested, undamaged cassava tubers, with stems attached, are arranged on the branches/leaves. This process is repeated until the trench is almost full. The final layer of branches/leaves is covered with soil, 7 to 10cm deep; the soil is moistened once a week with clean water (see Figure 8.2).

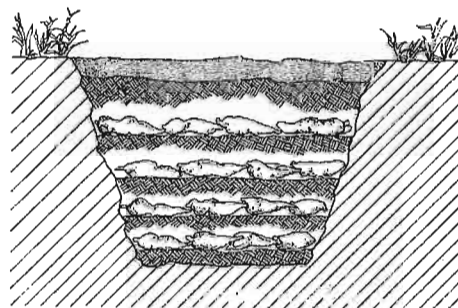

Figure 8.2
Cassava tubers stored in a trench, covered with soil

Storage in sawdust

Cassava tubers stored in sawdust must be freshly harvested with 15 to 20cm of the stem attached. The three types of containers which can be used for this method are woven baskets, paper cartons and wooden boxes with covers (see Figure 8.3). Tubers can be stored by this method from 6 to 8 weeks.

A layer of sawdust is spread at the bottom of the container. A layer of fresh cassava tubers, carefully arranged so that the tubers do not touch each other, is then placed on the sawdust. Another layer of moist sawdust is put on the tubers, followed by second layer of tubers. Sawdust is packed between the tubers and also at the top of the container, and is then moistened. The containers can be transported or stored in this way.

It is essential in this type of storage to inspect cartons every 3 days to ensure that the sawdust is moist. It is also important to ensure that the harvested cassava tubers have no mechanical damage, as this method is suitable only for storing undamaged tubers.

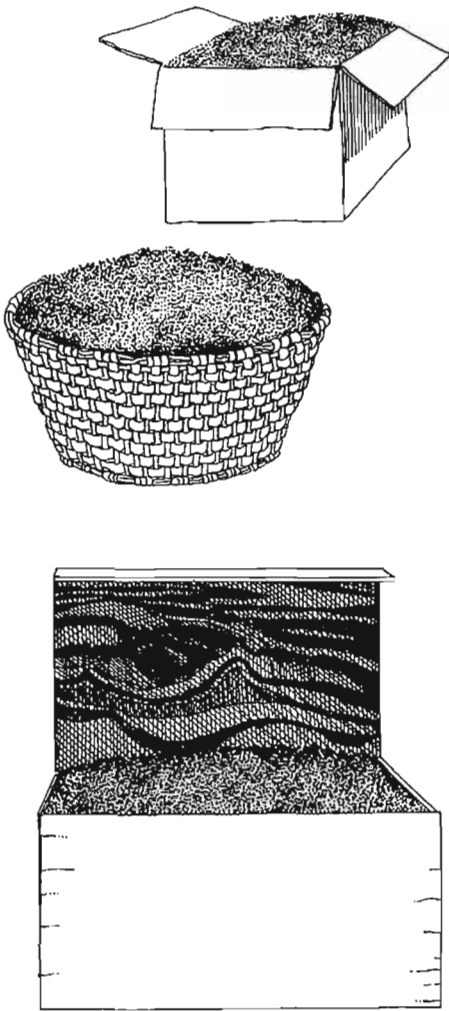

Figure 8.3

Three types of containers used for storing cassava tubers in sawdust

UNIT 9

Cassava Processing

Cassava consists of 60 to 70% water. Processing it into a dry form reduces the moisture content and converts it into a more durable and stable product with less volume, which makes it more transportable.

Processing is also necessary to eliminate or reduce the level of cyanide in cassava and to improve the palatability of the food products. Processed cassava products are also used as raw materials for a number of small- or medium-scale industries in Africa.

The tubers and leaves of cassava contain cyanide which can be poisonous, depending on the levels in a particular variety. Thus, to ensure they are safe for human consumption, the cyanide must be removed or considerably reduced. According to the processing procedure used, the percentage of cyanide reduction varies from 69.85 to 100%.

The tubers are detoxified by hydrolysis of linamarin and lotaustralin into HCN (hydrogen cyanide) which is volatile and evaporates rapidly at temperatures above 28°C. Some measure of detoxification can also be achieved by mechanical disintegration (pounding, grating or chipping the tubers).

The objectives of cassava processing are to:

- reduce postharvest losses of fresh tubers
- eliminate or reduce the cyanide content
- improve the taste of cassava products
- provide raw materials for small-scale, cassava-based rural industries

Traditional methods of cassava processing

Traditional cassava processing technologies can be divided into three main groups:

- preparation of cassava chips and flour (unfermented or fermented)
- technologies based on fermented cassava dough
- minor technologies

Cassava chips and flour

Preparation of unfermented cassava flour. This process is suitable for low-cyanide cassava varieties only. The cyanide content in these varieties is 5mg or less per 100g of fresh weight, whereas in high-cyanide cassava varieties the cyanide content is 10mg or more per 100g of fresh cassava. Flour prepared from high-cyanide cassava and used for food preparations may result in acute cyanide poisoning. An example of unfermented cassava flour is 'kokonte', in Ghana.

The traditional process for preparing unfermented cassava flour is as follows:

1. The cassava tubers are peeled manually.
2. The peeled tubers are washed.
3. They are then cut into chunks (in some countries, including Rwanda and Zaïre, the peeled and washed tubers are dried as whole tubers).
4. The cassava chunks are dried on the ground (or, rarely, on elevated platforms); drying takes from 2 to 5 days, depending on the weather.
5. The dried cassava is normally stored in the form of chips in jute sacks and then sold, or it is milled for family use when necessary.

Preparation of fermented cassava flour. In Nigeria, fermented cassava flour is known as 'lafun'. It is particularly popular in the

south-western states of Lagos, Ogun, Ondo and Oyo. There are slight variations in the preparation of lafun, depending on locality, but basically the process is as follows:

1. The cassava tubers are washed (in areas with water supply problems, this step is often omitted).
2. The tubers are steeped in water, usually in drums, pots or natural ponds in areas close to cassava farms. It is during this stage that the fermentation occurs. The minimum time for fermentation is 3 days; the process is slower in the rainy season than in the dry season.
3. The fermented cassava tubers are peeled. After fermentation, the peel comes off easily, as a result of partial disintegration of the cassava tubers.
4. The tubers are then dehydrated by putting them into bags and placing stones on top of the bags.
5. The dehydrated, pulverized mash is sun-dried in thin layers on mats, concrete surfaces or, very often, on rocks. Drying the mash on rocks has the advantage of allowing drying to continue overnight because the rocks absorb heat during the day and give it out at night. Drying takes from 1 to 3 days, depending on the weather.
6. The dried cassava is milled and stored for household consumption and sale.

To produce better-quality flour, the tubers are peeled before steeping in water, and disintegration is carried out using a cassava grater set for larger clearance.

Deficiencies of traditional flour preparation methods. The deficiencies of preparing unfermented and fermented cassava using the traditional methods outlined above are as follows:

- Although drying the chunks or the whole tubers usually results in their outer surfaces being sufficiently dry, the moisture level inside the chunks or tubers is still considerably higher than its safe value.
- The process is quite unhygienic; spreading the product on the ground makes it vulnerable to contamination by, for example, foreign bodies or dust.



Figure 9.1
Steeping cassava tubers for the preparation of lafun



Figure 9.2
Drying manually pulverized cassava on natural rocks

- Drying causes a major bottleneck in flour production, particularly during the rainy season when the product can become moldy and lose quality.

Fermented cassava dough

The most typical and popular product which is prepared from fermented cassava dough in West Africa is gari. Gari is a free-flowing product, consisting of cassava particles which have been gelatinized and dried. The size of these particles varies from one locality to another according to consumer preferences; a finer gari is produced by sieving the product after roasting. Gari is creamy-white or yellow, depending on the type of cassava used or whether palm oil has been added.

For good storability, the moisture content of gari should be below 12%, preferably 8 to 10%. Good-quality gari swells to about three times its initial volume when placed in water. The popularity of gari is probably based on the fact that the granules are precooked and a very short time is needed to prepare them as main dishes or snacks. An additional advantage is that well-prepared gari stores well for at least 12 months.

Traditional gari preparation. The traditional process for preparing gari is as follows:

1. The tubers are peeled manually. Usually, this is a family or group activity, with women helping each other or being hired by processors (*see Figure 9.3*)



Figure 9.3
Peeling cassava manually

2. The peeled tubers are washed (this step is sometime omitted in areas with water shortages).
3. The peeled tubers are grated. This is usually done with hand graters (perforated tin sheets, nailed to a bench or set in a frame), but mechanical graters are available and are being used in some areas (see Figure 9.4.)
4. The grated cassava mash is fermented and dehydrated. This is done by putting it in sacks. Logs or stones are placed on top of the sacks or, alternatively, the sacks are pressed between two boards attached by ropes; as the ropes are tightened, the water is squeezed out from the cassava mash. Fermentation usually takes from 3 to 5 days, but in localities where a bland gari taste is preferred (for example, Bendel State in Nigeria) the mash is fermented for only 1 day (see Figure 9.5). Fermentation is very important because it gives gari its preferred sour flavor, and detoxifies the cyanide. The safe level of cyanide in gari as specified by the Nigerian Food and Drug Administration is 10ppm (1 mg HCN per 100g of gari); the cyanide level for low-cyanide cassava is 50ppm (5mg HCN per 100g of fresh tubers).



Figure 9.4
Grating the tubers manually



Figure 9.5
Dehydrating and fermenting cassava mash



Figure 9.6
Sieving cassava mash

5. Sieves made of plant material are used to separate the gari particles and to remove fiber and poorly grated material (see Figure 9.6).
6. The particles are then ready for frying. Gari frying can be seen as two processes: starch gelatinization of the particles, and

drying. The particles are fried in shallow earthenware, aluminium or iron cast fryers (see Figure 9.7). In certain parts of Nigeria, an oil drum, cut longitudinally and set into a specially prepared fireplace, is used. Palm oil is added to the frying surface to prevent burning or to give the gari a yellow color. During the frying process, a calabash or a little broom is used to toss the particles.



Figure 9.7
Frying gari

7. The fried particles are cooled by spreading them on a floor; the floor is usually covered with some sort of sheeting.



Figure 9.8
Gari being sold

8. The cooled gari is sieved with locally made sieves to ensure uniformity of grain size. Large particles are normally milled and added to the sieved gari. This is then packed in polyethylene bags, jute sacks, propylene sacks or paper bags, and marketed.

Deficiencies in traditional gari production. The deficiencies in the traditional gari production process are as follows:

- Manual peeling results in low productivity. Attempts to mechanize peeling have not been successful because of the irregular shape and size of cassava tubers. However, for small- and medium-scale processing, manual peeling has the advantage of providing part-time work for women and children in rural areas.
- Grating normally results in low output (not more than 20kg of cassava can be grated per day), and may cause injuries to fingers.
- Gari fryers often have a fuel efficiency of less than 10%, and frying exposes those cooking the gari to heat, smoke and cyanide fumes.
- There is often little or no quality control of the finished product, which may result in the product having a higher moisture content than recommended, making it unsuitable for long-term storage. Sometimes, to save on fuel, gari is deliberately removed from the fryers before its moisture content has been sufficiently reduced, and then sun-dried. This practice gives satisfactory results during the dry season, but in the rainy season gari reabsorbs the moisture and becomes unsuitable for storing for more than 1 week.

Minor processing technologies

In all cassava-growing areas in Africa, starch is produced in small quantities. The process involved in starch production is summarized here:

1. The cassava tubers are peeled and washed.
2. The tubers are grated or pulverized.
3. The cassava mash is mixed with large quantities of water and sieved to extract the starch.

4. The starch granules are allowed to settle overnight.
5. The water is decanted, and the starch cake which settles at the bottom of the container is broken into pieces for drying; often it is sold as wet chunks.
6. The wet starch is sun-dried for 1-2 days.

Deficiencies in traditional starch production. The problems associated with traditional methods used for starch production are as follows:

- Manual grating, especially when poor-quality graters are used, has low productivity and does not allow starch to be released from the cells efficiently.
- Sun-drying is difficult during the rainy season and often results in contamination of the finished product.
- The quality of starch depends on the quality of the water.
- There is no quality control of the finished product.

Improved cassava processing

Compared to the traditional methods, the improved method for processing cassava increases productivity and improves the quality and storability of cassava products. It also enhances the potential for cassava growers in Africa to develop non-traditional cassava products (such as cassava starch, an important raw material in the food, textile, paper and other industries; cassava flour, for use in various bakery preparations, alone or as composite flour; and cassava chips and pellets, which are incorporated in animal feed rations by EEC countries because of the low price and high energy content of cassava compared with cereals).

The objectives of improved cassava processing are:

- to reduce the drudgery and labor intensiveness of traditional cassava processing methods, and thus increase productivity
- to produce an end product of better and more uniform quality
- to ensure the reduction or total elimination of undesirable toxic constituents in cassava so that it is suitable for human consumption

- to promote the establishment of economically viable small- and medium-scale cassava-based industries and create new opportunities for employment in rural areas
- to reduce the amount of fuel used for drying cassava by introducing fuel-efficient devices and techniques
- to promote the export potential of cassava products such as starch and cassava chips and pellets

Improved cassava processing for three cassava products — gari, cassava chips and flour, and cassava starch — is presented in detail below. These specific cassava products have been selected because:

- they are relatively easy to manufacture within the existing infrastructures of the rural areas in Africa
- they could play an important role in the food security of rural communities
- the machinery required to process them is or can be manufactured by the informal engineering sectors of many African states
- they provide the raw material for a number of important industries

Gari

A flow chart depicting the improved gari processing method is presented in Figure 9.9; the moisture content of the cassava product at each stage of the process is indicated. Illustrations of various stages of the process are provided in Figures 9.10 to 9.13 (see overleaf).

Raw material requirements. The ratio of the fresh unpeeled cassava input to gari output is approximately 5 : 1 (that is, 2 tons of fresh cassava are required to produce approximately 400kg of gari). However, these figures are not absolute because many factors affect the ratio of output to input, such as type of cassava used, thickness of peel, age of cassava and moisture content. It is important to weigh the cassava before and after peeling.

Peeling and washing. Attempts to mechanize the peeling of cassava have not been successful because of the irregular shape

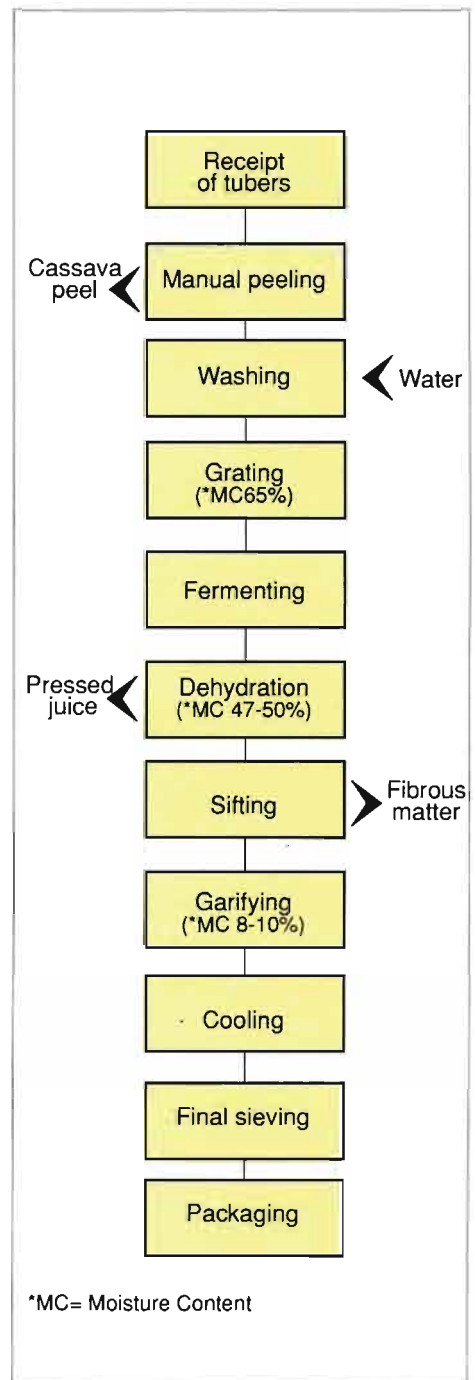

Figure 9.9
Flow chart of gari manufacture

and size of the tubers. Manual peeling with stainless steel knives is recommended.

The peeled tubers are washed and packed in woven baskets to allow the water to drain. The tanks in which the tubers are washed should be made of stainless steel, plastic or ceramic material; if these are not available, galvanized steel tanks may be used. After washing, the tanks are cleaned and dried.



Figure 9.10
Washing and grating cassava tubers



Figure 9.11
Power screw dehydrating press

Grating. The washed tubers are conveyed with wheelbarrows or other means to the cassava grater. These graters vary in size and shape but basically they all have a rotating drum covered with a perforated metallic sheet. By attaching a discharge chute to the grater, the grated cassava particles can be delivered straight into bags (made of polypropylene or other materials) for fermentation.

Fermentation. Fermentation racks are built from wood and have drainage lanes directly beneath them to allow the juice from cassava to flow out. Fermentation takes 1-5 days, depending on the preferred gari flavor in a given locality.

Dehydration. Some water drains through the holes in polypropylene bags during the fermentation stage. However, most of the moisture is removed by using power screw presses; two people operate the extension arms of the screw shaft. The moisture of the dehydrated cassava mash is 47 to 50%.

Sieving. Dehydration produces cassava cake which has to be sieved before frying. Sieving machines or sieves made of plant material are used. The cassava cake is pressed or rubbed against the surface of the sieve.



Figure 9.12
Mechanical sifter for cassava mash and gari



Figure 9.13
Frying gari (improved)

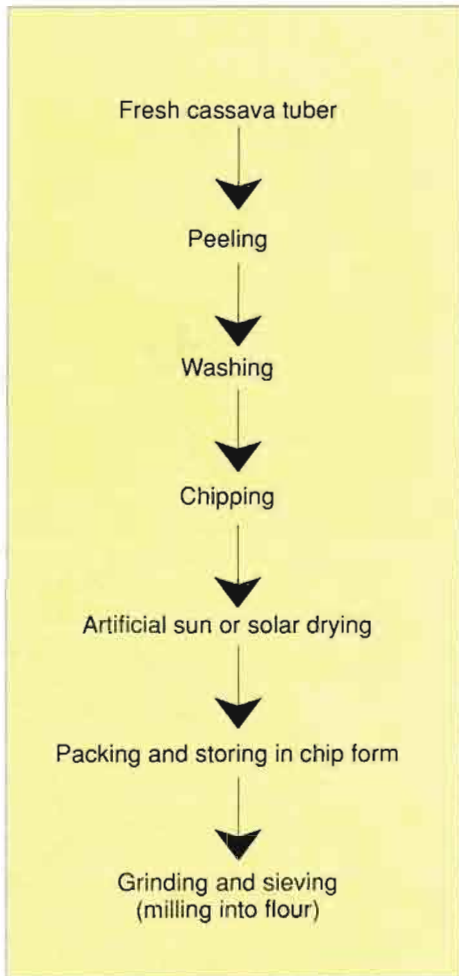

Figure 9.14
Flow chart for preparation of chips and flour from low-cyanide cassava varieties

Frying. The cassava particles are fried on metal trays measuring 1.2 x 2.4m and fixed into a fireplace built of bricks or mud blocks. The fireplace has a chimney to allow smoke to escape and to improve heat efficiency. The particles are fried until crisp and dry. The recommended moisture content of the finished gari is about 10%; this can be tested with a moisture meter.

Cooling. The gari is cooled by spreading it out on polyethylene sheets on the floor. It can be cooled overnight and packed in the morning.

Final sieving and packing. The cooled gari is sieved again to ensure uniformity of the final product. It is then packed.

Cassava chips and flour

Using low-cyanide varieties. The process to be followed in the preparation of dried cassava chips and flour from low-cyanide cassava varieties is shown in Figure 9.14.

Notes on preparation method

1. The ratio of the cassava chips output to fresh cassava input is approximately 1 : 4. Depending on the type of cassava used, 1 ton of cassava tubers gives 250kg of cassava chips.
2. It is recommended that peeling is done with stainless steel knives.
3. Peeled cassava should be washed in cemented tanks or plastic drums, to avoid adverse effects of corrosion.
4. Washed cassava may be sliced using manual or mechanical slicing machines.
5. During the dry season it is convenient to sun-dry chips on elevated platforms built in an open area, about 900m². However, during the rainy season such an arrangement is not satisfactory, and some sort of enclosed drying chamber using solar energy or fuel is recommended. Drying is done until the chips have a moisture content of 8 to 10%, after which the chips are cooled and packed.
6. Cassava may be stored as chips and milled into flour when needed; chips store better than flour. There are many types of grinding machines in use in urban and rural areas in Africa.

Using high-cyanide varieties. This process for preparing cassava chips and flour from high-cyanide cassava was developed by the Ceylon Institute of Scientific and Industrial Research in Sri Lanka (see Figure 9.15). It removes 95% of the cyanoglucosides in cassava.

The first drying stage disrupts the cell membranes of the cassava tissue, causing increased permeability. Soaking in water results in a loss of a large fraction of soluble material, including free HCN, glucosides and cyanohydrins. By the end of the second drying stage, 90% of the HCN has been removed. Drying at 100°C causes quick decomposition of cyanohydrins and thus almost total removal of cyanide.

Flour prepared in this way can be used for various purposes (for example, in the paper industry, and in the textile industry for cotton warp sizing and textile finishing). The peels may be dried, soaked, redried, ground and used as poultry or cattle feed.

Traditionally, grinding chips into flour is done manually by pounding them in a wooden mortar. However, grinders are now common in rural and urban Africa, particularly the serrated plate type.

Notes on preparation method

1. Freshly uprooted cassava is preferred because it gives a better-quality product. However, tubers which are from 1 to 3 days old may be used if there is no obvious spoilage.
2. Chipping is done manually or with mechanically operated chippers; the thickness of slices is 4mm.
3. In the first drying stage, the sliced chips are dried in the sun for about 3 days to a moisture content of 14%. Drying is done on trays made of wood or other plant material. During the rainy season, protected solar driers are recommended.
4. The chips are soaked in water for 8 hours in tanks; a drain leads from the tank. The ratio of water to chips is 1 gallon of water to 1 pound of chips.
5. The second sun-drying stage takes 1 or 2 days.
6. Dried chips are placed in an oven at 100°C for 2 hours and dried to a moisture content of 6 to 8%. Ovens with a capacity to dry 200kg of chips per batch and handle about four batches a day may be used.

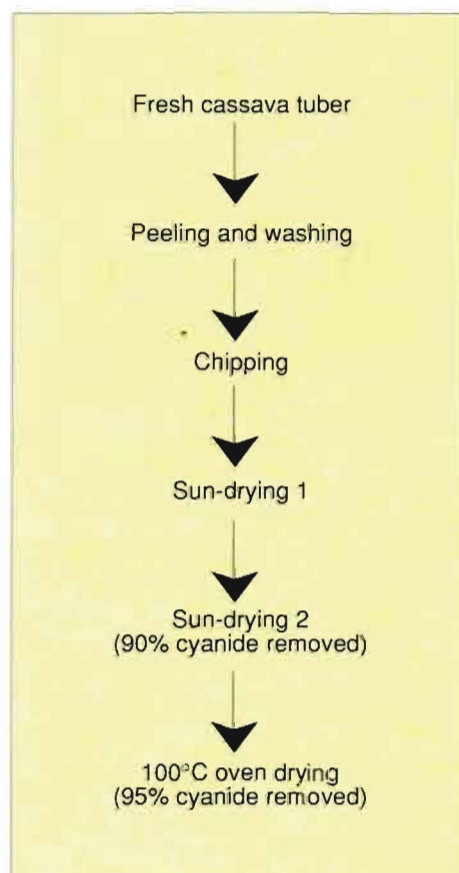

Figure 9.15
Process flow chart for preparation of detoxified flour from high-cyanide cassava varieties

Cassava starch

Cassava starch is an important industrial raw material which is used in the manufacture of a number of products, including food, adhesives, thickening agents and pharmaceuticals. The process for improved starch production, shown in Figure 9.16, is very similar to the traditional process. It is based on a maximum production of 200kg/day, which is the capacity for an average rural starch factory.

Notes on preparation method

1. When selecting tubers for starch production, age and tuber quality are the critical factors. Tubers contain 20% starch by weight, but as a result of losses during processing this is reduced to 10%. Thus, 1 ton of cassava produces 100kg of cassava starch.
2. Manual peeling is still the cheapest way of peeling cassava; 18% loss of weight is assumed.
3. The peeled tubers are washed in cemented tanks. As water quality is not critical at this stage, stream water can be used.
4. Grating is important because it affects the quantity of the starch released from cassava. The percentage of starch set free is called 'rasping effect'. Its value after one rasping varies between 70 and 90%. Secondary grating using a hammer mill with a fine screen is recommended.
5. The starch is washed out using clean water. If the water contains ferrous compounds, a simple filtering system may be used. If piped treated water is available, filtering is not necessary.

For a 200kg/day starch production, the cheapest way to wash out the starch is to use a woven basket with a piece of clean calico cloth tied around the outside. This forms a double sieve. The grated pulp is put into the basket and handwashed with water until no more milky starch comes out. The remaining pulp is discarded. The milky starch solution is collected into plastic drums (30-gallon drums are a convenient size for starch removal) and left to settle overnight.

The discarded pulp can be fried into gari or dried and incorporated in animal feed. Gari from discarded pulp is of inferior quality.

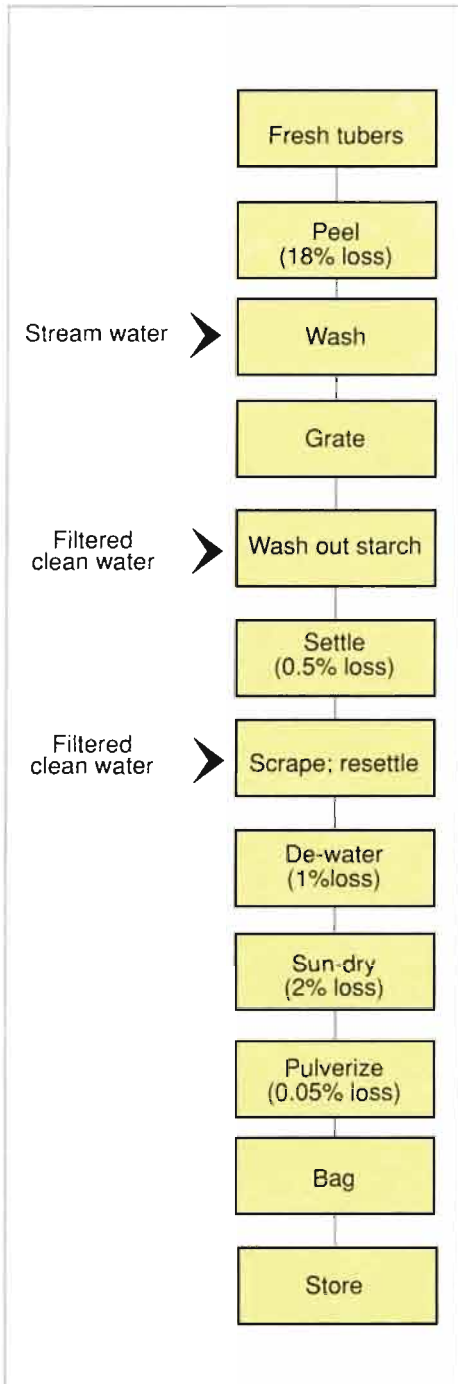

Figure 9.16
Process flow chart for manufacture of cassava starch

- 6/7. After it has settled overnight, the clear water is drained off and the top surface of the starch cake is scraped clean; the bottom part of the cake may also need scraping. The starch is then dug out in lumps, which are again mixed with water and allowed to settle overnight. This process may be repeated the following day to get good-quality starch free of any dirt.
8. After the final settling, a clean starch cake results which is broken into small bits by hand in preparation for drying. The crumbling can be done with sieves, similar to those used in the production of gari.
9. Drying is done in ovens if the quantity of starch produced is above 1000kg per day. For small quantities, sun-drying is used. Starch is deposited on trays which are placed on racks, about 1m above the ground at an angle of about 30°. These simple measures increase the drying speed by a factor of 3. If the starch is not dry by the evening, the trays are stacked inside and returned to the racks in the morning. Solar dryers may be useful in speeding up the drying process.

An important advantage of sun-drying is the bleaching action of the ultraviolet rays of the sunlight. The starch is dried to not more than 12% moisture content. During the rainy season, when it is difficult to sun-dry starch, it is recommended that drum dryers are used to facilitate the drying process.

Establishing a cassava-processing cottage industry

This section outlines the measures to be taken in establishing a rural cottage industry producing gari, cassava flour and cassava starch.

When deciding on the location of the industry, two important factors must be taken into account: fresh cassava tubers have a high moisture content and are therefore bulky and difficult to transport; and cassava is a highly perishable commodity. For these reasons, the industry should be located within the cassava-producing area or not more than 20km away from it; and links should be established with farms or plantations capable of supplying not less than 50% of the industry's annual raw material requirements.

A separate economic viability analysis should be undertaken for each locality before a cassava-processing industry is established.

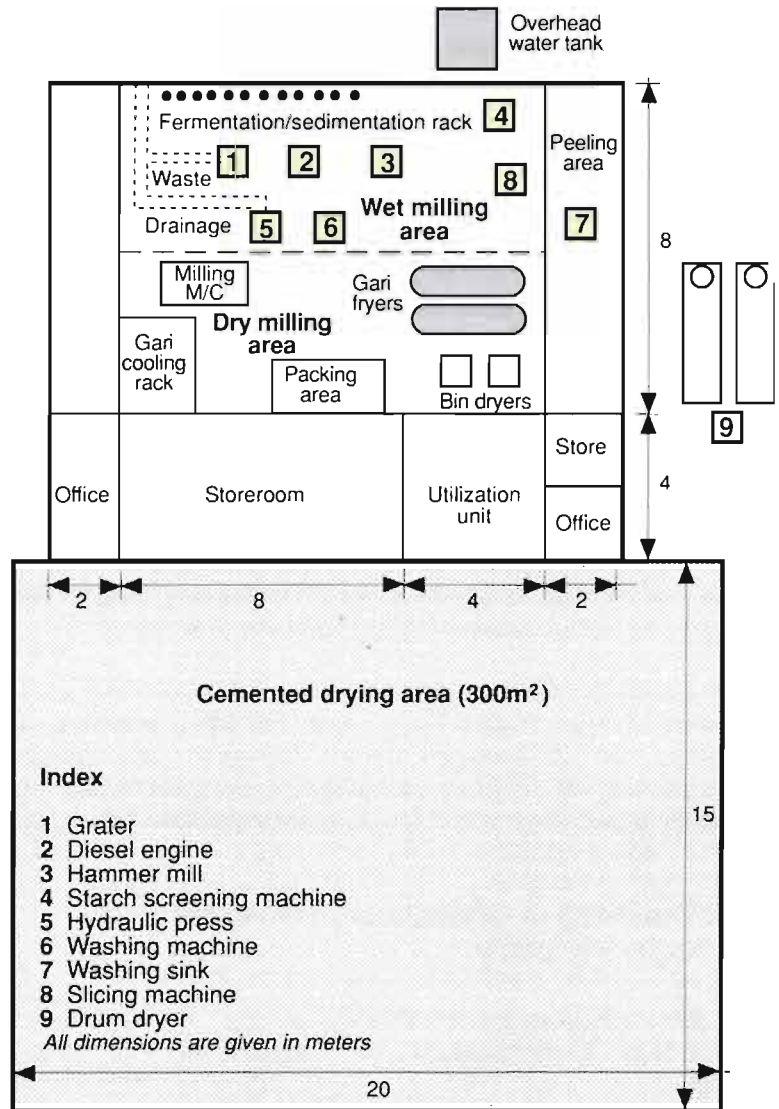

Figure 9.17
Layout of rural cassava-processing industry

The profitability of such an industry depends on many factors quite independent of its technical viability, such as government policies, supply and price of cassava, and the comparative price of the imported commodity which may be substituted.

Where a market for non-traditional cassava products has not been developed and is therefore unpredictable, it is more practical for the cottage industry to produce a few cassava products instead of

concentrating on only one. This allows the flexibility to switch quickly to the product for which a market demand exists, and will also make maximum use of those implements and machines that can be used for processing different types of cassava products (for example, graters are used for both gari and starch production). The recommended output from the industry is: 400kg/day of gari; 250kg/day of cassava chips and flour; and 200kg/day of starch.

Structure and design

Figure 9.17 (*opposite*) presents the recommended layout of a rural cassava-processing industry. To reduce the cost of construction, it is an open structure, apart from the section where the finished products are stored; this area should be walled to the roof.

The dry milling area should have a concrete floor which is about 18cm thick; the floor of the wet milling area should also be concreted but about 8cm lower than the dry area. Alternatively, a cement wall about 15cm high can be built to separate the two areas.

The sink for washing tubers is 60cm deep and fitted with a tap and drainage pipe; it stands on a 60cm-high plinth. Some space is provided within the structure for stacking the starch/chips drying trays during the night. Wooden battens laid between each layer of trays allows air to circulate. The drying racks outside are made of bamboo poles. The center pole is about 10cm higher than the others to provide the necessary tilt.

Machinery and implements

The type and quantity of implements and machinery required for a rural cassava processing industry are given in Table 9.1 (see *overleaf*).

Machinery for processing gari. The gari-processing machinery itemized in Table 9.1 is described here, apart from the petrol and diesel engines.

Cassava grater

The cassava grater (stationery or mobile) has become a permanent feature of cassava processing in rural communities. These graters can grate at least 4 tons of fresh tubers per day, and thus only one is needed to handle all the gari/starch processing operations of a rural industry.

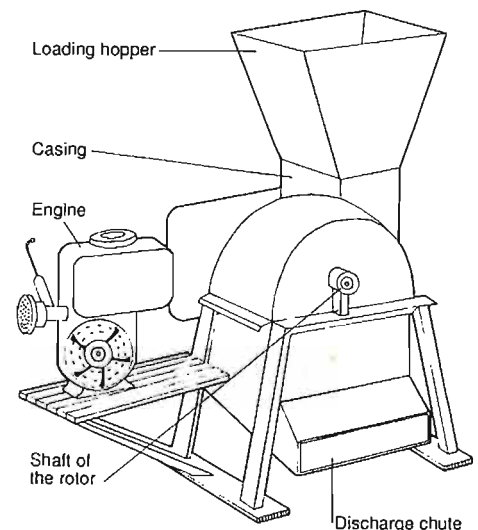

Figure 9.18
A typical cassava grater

Table 9.1

Machinery and implements for rural cassava-processing industries

Item	Quantity	Description
Machinery for gari		
Cassava grater*	1	Powered by 5hp diesel engine
Cassava press	1	Output 500kg/hr; manually operated
Diesel engine	1	Screw type; 5hp
Sieving machine	1	Powered by 3hp petrol engine
Gari fryer	2	200kg/day capacity
Petrol engine	1	3hp
Machinery for cassava chips and flour		
Slicing machine	1	300kg/hr
Dryer	1	Bin type; 200kg/day
Milling machine	1	5hp engine 500kg/hr
Machinery for cassava starch		
Drum dryer	2	50kg/hr
Implements and accessories		
Knives (for peeling cassava)	20	Stainless steel
Plastic drums	30	For fermentation
Fermentation racks		Made of wood
Drying trays	100	Made of local wood and plastic net; 0.7x 1.0m
Basket for sieving starch	10	Local type
Moisture meter	1	Multipurpose, suitable for grains and flours
Weighing scale	1	For fresh cassava up to 200kg
Weighing scale	1	For finished product up to 10kg

Note: The cassava grater is used for both starch and gari production

A typical cassava grater incorporates a cylindrical, rotating, wooden drum which is covered with a nail-punched metal sheet (galvanized or tin), as shown in Figure 9.18. The rotary drum is set into a casing, with the critical dimension being the clearance between the lower part of the drum and the casing; this clearance determines the size of the grated particle.

The output of the grater varies from 500kg to 1000kg per hour, depending on the diameter and speed of the rotary drum and the number of perforations per unit area of the drum surface; these parameters have not been standardized.

When selecting, installing and using the grater, it is important to ensure that:

- the grating surface is constructed from non-corrosive material
- the perforated grating surface is easily replaceable when it becomes worn
- the grater is built on a platform so that the cassava mash can be easily and hygienically discharged directly into a fermentation sack or container
- there is little or no contact between the expressed cassava juice and the wooden drum of the rotor (otherwise, the drum will deteriorate fast and bits of wood will get into the cassava)
- the grater is thoroughly washed after each day of operation to ensure long-term use and hygienic processing

Dehydration press

The most durable and convenient dehydration press for small-scale production is the power screw de-watering press (see Figure 9.11). The dehydration press incorporating a hydraulic jack (see Figure 9.19) is faster and less labor intensive; however, the seals wear out rapidly, and replacing them may be difficult. The cassava juice expressed during this operation can be collected for starch.

Sieving machine

Cassava particles are always sifted before and after the garifying (frying) operation. This can be done easily with a sieving machine powered by a 1.5kw electric motor or diesel engine (see Figure 9.12). The sieving trays have holes of different diameters, so that the machine can be used for sieving both uncooked and fried gari particles. However, sieving raw cassava particles is better done by feeding the cassava cake back into the grater after dehydration (see Figure 9.18).

In the absence of a sieving machine, a manual bamboo sieve (300-400 microns in sieve size) can be used.

Gari fryers

Many types of gari fryers, both mechanized and manually oper-

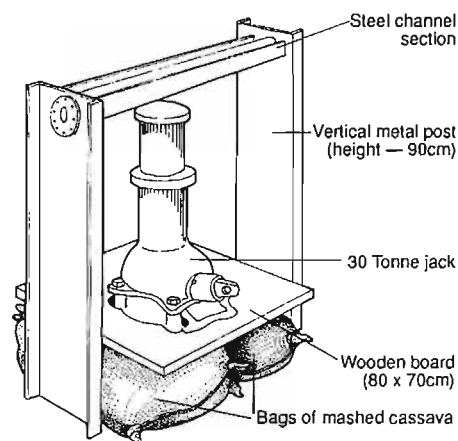

Figure 9.19
Hydraulic jack press

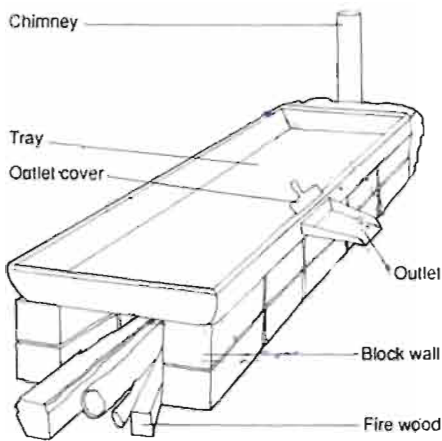

Figure 9.20
RAIDS gari fryer

ated, have been developed in West Africa. The most cost-effective type in industries producing less than 500kg of gari per day seems to be the RAIDS gari fryer (see Figure 9.20). It consists of a rectangular tray set into a brick fireplace with a chimney. The tray is made of 3mm-thick mild steel sheets and has a side opening for discharging the finished product. To produce 400kg per day, two gari fryers are required.

Machinery for processing cassava chips and flour. The three items required for processing cassava chips and flour are a slicing machine, drying equipment (for natural or artificial drying) and a milling machine.

Slicing machine

A mechanized or manually operated slicing machine (see Figure 9.21) is an important investment for producing cassava slices of uniform thickness to ensure more uniform drying. It will save time and energy, improve productivity, increase the surface area available for drying and produce better-quality chips and flour.

Slicing machines are popular in Asia but uncommon in West Africa. The type used in Asia consists of a steel framework supporting a feed hopper, a casing containing the rotor disc and a petrol/diesel engine. The cutting drum is fitted with four blades which rotate at about 500rpm. The size of the cassava chip is 10cm x 10cm x 50cm; the optimal thickness of the chip is 6mm for through-flow drying and 10mm for cross-flow drying. The machine produces 1 ton of chips per hour, and a single machine is adequate for a rural cassava-processing industry.



Figure 9.21
Manually operated slicing machines

Dryers

Drying is carried out to reduce moisture content and is essentially a process of simultaneous heat and moisture transfer. Heat is required to evaporate the moisture from the inside and the surface of a product by an external drying medium, usually air. In a number of agricultural crops, including cassava, the drying of single particles under constant external conditions exhibits a constant-rate moisture loss during the initial drying period, followed by a falling-rate moisture loss. This implies that the drying rate decreases continuously during the course of drying.

Drying methods can be classified as natural or artificial.

(a) In natural drying, the material is subjected to the combined action of sun rays and atmospheric air. Natural drying can be divided into three categories: sun drying, solar drying and natural ventilation.

- Sun drying. This is the most common method of drying in Africa. The material is spread on the ground, roof top, compacted soil, concrete floor or, more rarely, on an elevated platform. The material is occasionally turned. There are numerous disadvantages to this method, such as reabsorption of moisture from the ground, uneven drying, insect and animal invasion, and exposure to dirt and dust.
- Solar drying. Sun drying can be speeded up through the introduction of solar dryers to enhance the effect of solar radiation. Solar dryers can be simple box structures covered with polyethylene sheets, plastic sheets or complex structures which incorporate blowers and transparent plastic sheets.
- Natural ventilation. Agricultural crops are sometimes put onto platforms where they are allowed to dry by natural air. The downward flow of air is increased by placing a windbreak in front of the platform.

(b) Artificial drying methods are those which use blowers, heaters and other external energy sources. In areas where solar radiation and relative humidity are conducive to sun-drying, sun-drying should be encouraged. Artificial methods should be used only as a supplement to sun-drying during the rainy season or during the night or early morning. The three methods of artificial drying described here involve the use of drying trays, artificial forced circulation dryers and solar dryers.

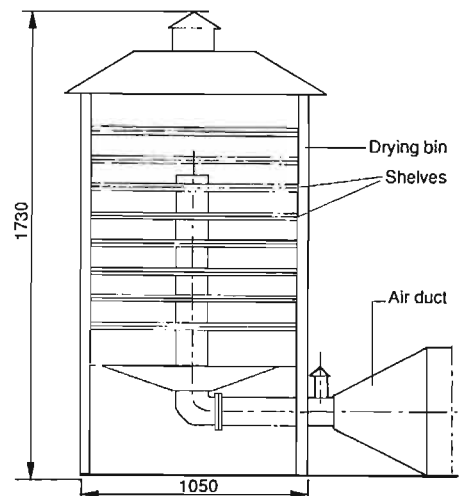
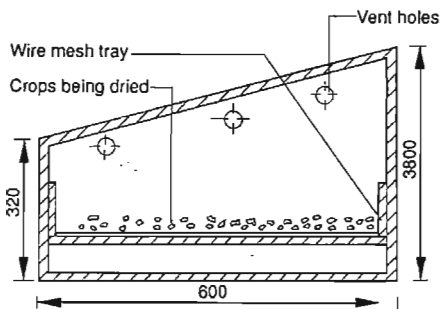
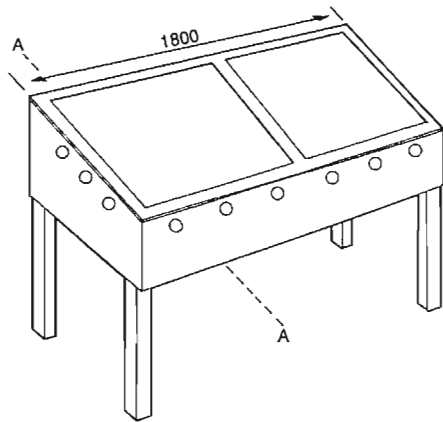

Figure 9.22
Multipurpose bin dryer



Section A — A

Figure 9.23

Cabinet dryer, showing cross-section (below)

- Drying trays, measuring 0.7 x 1 m, can be made of plant material, but investing in more durable plastic mesh/netting or wooden trays is more cost-effective in the long run. The chips are laid on the trays (about 10kg per square meter); the trays are placed on specially built racks inclined at a 25 to 30° angle. The number of trays needed depends on the rate of production of the chips.
- During the rainy season, when it becomes impossible to dry cassava chips outside, artificial forced circulation dryers can be used. A suitable design is shown in Figure 9.22 (on page 107). The drying chamber is made of plywood, and the product to be dried is arranged on the shelves. The air is blown by a centrifugal blower into a heat exchanger which consists of a series of pipes set in a fireplace with a chimney; the blower is driven by an electric motor or a small petrol engine with a power of 0.7 to 1.0kw. The air is heated by the pipes and passes into the drying chamber; here it picks up moisture from the product and escapes through the opening at the top of the drying chamber. About 500kg of cassava chips with a moisture content of 12% can be dried in 40 to 48 hours. The blower is driven by an electric motor or a small petrol engine with a power of 0.7 to 1.0kw.
- Solar dryers, such as the cabinet dryer shown in Figure 9.23, can be constructed from locally available materials. They enhance the insulation effect and contribute towards the generation of higher air temperatures and lower relative humidities, both of which are conducive to improved drying rates and lower final moisture content of the dried crop. The higher temperatures also deter insect and microbial infestation.

Milling machine

The most common type of mill used in Africa for grinding chips into flour is a plate mill. This has stationary and rotating serrated plates. The clearance between these plates regulates the degree of fineness of the milled product. The output of the milled material depends on the size of the plate and the power of the motor or engine.

Another type of milling machine, the hammer mill, has a series of reversible, flexible hammers fixed radially inside the casing (see Figure 9.24). The material is fed through the hopper, and moved over the wire mesh screen by the hammers; the size of the milled particle is regulated by the screen.

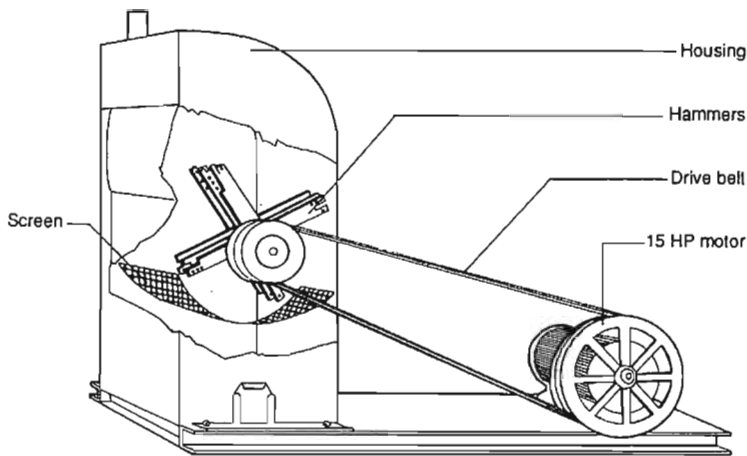

Figure 9.24
Hammer mill

Although the hammer mill uses less energy to produce the same output as that produced by the plate mill, it is not as suitable for small-scale rural cassava-processing industries as the plate mill because:

- the availability of spare parts for the hammer mill in most cassava-growing areas in Africa is limited (for example, it is necessary, to replace the screen regularly, and obtaining a new screen often poses problems)
- it can be used only for dry material, whereas the plate mill can be used for grinding both wet and dry material

Machinery for processing starch. The Brook dryer is a simple device which consists of three 200-liter drums and a screen. The drums are laid end to end and are joined together, as illustrated in Figure 9.25. Above the drums is the screen. A fire is built in the first drum, and the warm air from the fire passes through the starch.

After being dried in the Brook dryer, the starch is ground in a plate mill and is then sieved. It is necessary to sieve the starch because the standard particle size for starch used for most applications is very small. However, if the demand for cassava starch increases, it may be necessary for the rural industry to invest in pulverizing equipment.

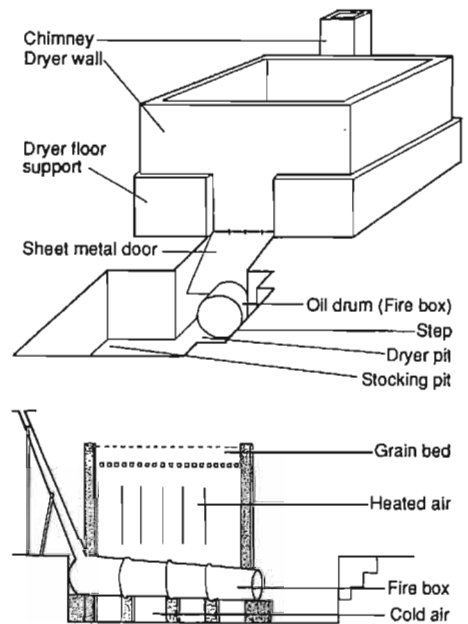

Figure 9.25
Brook dryer, showing cross-section (below)

Packing and storage

A number of African research institutions, including the Nigeria Stored Products Research Institute (NSPRI), have analyzed the suitability of locally available packaging methods for long-term storage of processed cassava products.

The most cost-effective storage measures are outlined below.

- Ensure that the product to be packaged is dried to a safe moisture content. The amount of moisture in an agricultural crop or product is the most important factor determining its storability. When determining the moisture content, it is important to ensure that:
 - (a) the sample is representative of the batch which is being examined and the samplings are sufficiently large
 - (b) the sample is kept in a sealed container before determining the moisture content

The amount of moisture in a sample of produce which does not decompose when the produce is heated can be determined by weighing some of the ground produce and then drying it in a forced draft air oven at a given temperature for a predetermined length of time. The drop in the weight of the produce is measured according to its initial weight (wet basis).

- Allow the product to cool sufficiently before packing it. Latent heat which is not released will later condense inside the sealed container, resulting in mold growth and insect development.
- The material which has been prepared according to the procedure described above can be stored in polyethylene-lined sacks or brown paper bags in quantities of about 25kg or more for at least 12 months. If the material is to be packed into smaller packages (in quantities of 2, 5 or 10kg), thick polyethylene bags with a gauge of at least 0.15mm should be used. The larger bags are tied with a piece of string, while the smaller bags are sealed.

It is important to note that if the moisture content of the flour or gari is not sufficiently low and the product is not intended for long-term storage, polyethylene or hessian sacks provide better conditions for short-term storage.

- Cassava chips store better than cassava flour. If flour is required, the cassava should be stored as chips and then milled into flour just prior to sale or immediate use. Cassava flour, like gari, can be stored in polyethylene or paper bags, as described above.
- A fumigant, in the form of a tablet, should be put inside the bags. Phostoxin is safe as long as the user follows directions for its use provided by qualified agricultural extension personnel.
- Measures to control rodents by mechanical or chemical means must be applied.

UNIT 10

Utilization of Cassava and its Products

Cassava is an important food in the tropical areas of Africa, Asia and Latin America. It is estimated that the crop provides about 40% of all calories consumed in Africa.

Cassava has often been considered an inferior food because the tuber is low in protein, essential minerals and vitamins (*see* Table 10.1). However, in many cassava-growing areas its use as food helps to alleviate problems of hunger and carbohydrate intake deficiency and thus its importance in terms of food security in these areas cannot be over-emphasized. In addition, cassava leaves are consumed as a vegetable in many parts of Africa. They constitute a good source of protein and essential nutrients (*see* Table 10.2).

A major drawback in the use of cassava is the cyanogenic glucosides which it contains and which, upon hydrolysis, produce the very toxic cyanide. Residual cyanide in improperly processed cassava foods contributes to the etiology of goiter and spastic paraparesis which are endemic in several African countries.

Cassava cultivars are generally classified into low-cyanide and high-cyanide varieties, according to their cyanogenic glucoside content expressed as cyanide. The leaves generally contain from 5 to 10 times more cyanide than the tubers. The cyanide content can be established only by chemical analysis of the leaf or tuber, and not by any particular morphological or organoleptic characteristic.

Utilization for human consumption

The cassava tuber is utilized in many food preparations in Africa. It provides most of the calories in a meal, while the vegetables,

Table 10.1

Composition of cassava products prepared traditionally in Cameroon*

	Raw peeled tuber	Tuber cooked in water	Bâton	Gari	Cooked gari	Cooked flour		Tuber, cooked and washed (<i>medua-me- mbong</i>)	Peeled, cooked and washed
						Steeped without peel	Steeped with peel		
Calories	395	394	399	400	400	400	397	399	395
Proteins (g)	1.51	1.49	0.85	1.25	1.25	0.75-0.87	0.91-1.79	0.83	1.95
Lipids (g)	0.4	0.1	0.1	0.7	0.7	0.2	0.3	0.2	0.3
Total carbohydrates (g)	9.63	96.8	98.1	96.9	96.9	98.2	96.7-97.2	98.6	96.0
Indig. carb. (g)	1.9	1.7	1.7	1.9	1.9	1.5-1.7	1.2-2.0	1.7	10.8
Ash (g)	1.77	1.61	0.98	1.13	1.13	0.74-0.77	1.14-1.27	0.34	1.71
Calcium (mg)	42	42	34	33	33	30-33	35-52	61	389
Phosphorus (mg)	122	110	62	61	61	43-49	49-73	39	45
Ca/P	0.34	0.38	0.55	0.54	0.54	0.61-0.76	0.64-0.71	1.56	8.6
Fe (mg)	2	2	15	5	5	1-3	3-41	1	13
Thiamine (µg)	96	71	46	60	38	28-44	58-80	14	52
Riboflavin (µg)	57	57	95	49	49	36-55	28-98	30	20
Niacin (µg)	1,611	1,450	756	1,128	1,151	574-777	864-1,395	161	17
Ascorbic acid (mg)	61	4	6	6	-	0	0	-	-

Note: * Per 100g dry matter

Source: Favler, J.C. et al. 1971 'La technologie traditionnelle du manioc au Cameroun: influence sur la valeur nutritive'

legumes and meat/fish provide the necessary protein, minerals and vitamins. Various types of cassava flour are cooked into thick pastes by adding water to the flour and stirring the mixture rapidly over the fire.

Over the years, cassava-consuming populations have developed various processing methods to detoxify cassava tubers and leaves, including boiling, drying, grating and fermenting. The efficacy of these methods differs considerably. It is highest for processes that

Table 10.2

Composition of cassava leaves and selected other foods in terms of per 100g edible portion, fresh weight

	Reference	Calories	Moisture %	Protein g	Fat g	Total carbohydrate g	Fibre g	Ash g
Cassava leaf, raw	a	91	71.7	7.0	1.0	18.3	4.0	2.0
	b	60	81.0	6.9	1.3	9.2	2.1	1.6
Chinese cabbage, raw	b	17	94.2	1.7	0.2	3.1	0.7	0.8
Spinach, raw	b	19	93.0	2.4	0.4	2.8	0.7	1.4
Soybean whole seeds salted, black	b	330	20.1	18.1	9.4	46.3	8.5	6.1
Wheat whole grain, hard	b	332	12.5	11.6	2.2	72.1	2.1	1.6
Maize, yellow	b	349	13.6	9.1	4.2	71.7	2.3	1.4
Rice, unhulled, rough	b	341	13.7	5.8	2.3	73.4	10.4	4.8

	Ca mg	P mg	Fe mg	Vitamin A β Carotene equivalent μg	Thiamine mg	Riboflavin mg	Niacin mg	Ascorbic acid mg
Cassava leaf, raw	303	119	7.6	11,775	0.25	0.60	2.4	8
	144	68	2.8	8,280	0.16	0.32	1.8	82
Chinese cabbage, raw	102	46	2.6	2,305	0.07	0.13	0.8	53
Spinach, raw	62	39	3.9	3,640	0.06	0.22	0.7	56
Soybean whole seeds salted, black	29	163	1.1	520	0.07	0.27	18.6	-
Wheat whole grain, hard	48	382	3.3	0	0.37	0.12	4.6	0
Maize, yellow	14	245	2.8	270	0.29	0.11	2.1	0
Rice, unhulled, rough	24	236	1.4	-	0.33	0.06	5.6	-

Source: a: Food Composition Table for Use in Africa. Food and Agric. Org. and US Dept. Health, Educ. and Welfare. 1968

b: Food Composition Table for Use in East Asia. Food and Agric. Org. and US Dept. Health, Educ. and Welfare. 1972

achieve tissue disintegration, such as grating, grinding and fermenting. The boiling of cassava leaves, after grinding, has seemed to be efficacious in detoxifying them.

The tubers of high-cyanide varieties and leaves of all varieties should be thoroughly processed in order to reduce the cyanide content to minimal levels. Only low-cyanide varieties are recommended for foods prepared from fresh cassava without grinding or fermenting.

Many traditional cassava-based food preparations of Asia and Latin America may be used alongside traditional African preparations. In addition, in many African countries home economists and nutritionists have developed a number of non-traditional foods by incorporating locally grown cassava into the recipe in place of exotic ingredients.

Some of the most common cassava-based foods in Africa are listed below.

<i>Abacha</i>	Boiled, shredded and dried cassava slices (similar to noodles); eaten in salads (Nigeria)
<i>Ampesi</i>	Boiled cassava tubers; normally eaten with vegetable/meat soups or stews (Ghana)
<i>Agbele kaklo</i>	Deep-fried snack in the shape of croquettes or balls prepared from grated cassava mash; eaten as snacks (Ghana)
<i>Akple</i>	Thick porridge prepared from a mixture of maize and cassava dough; eaten with okra soup or stew (Ghana)
<i>Attieke</i>	Steeped, pounded, fermented cassava tubers which are pressed, crumbled and steamed; eaten with milk or meat and vegetables (Côte d'Ivoire)
<i>Bâton du manioc</i>	Wet cassava paste wrapped in leaves, shaped as a long stick (30 to 60cm) and cooked (Cameroon)
<i>Chickwangué</i>	Like bâton du manioc, but shaped into a ball (Cameroon)
<i>Elubo lafun</i>	Thick paste prepared from traditional cassava flour (lafun); eaten with vegetable/meat soup (Nigeria)

<i>Fufu</i>	Boiled cassava pounded with plantain or with cocoyam; eaten with various soups (Ghana)
<i>Foofoo</i>	Soaked, pounded and fermented mash which is then mixed with water, sieved, and cooked into a thick paste; eaten with stew (Sierra Leone)
<i>Gari (garri)</i>	Grated, fermented, sieved and fried cassava mash; in its final form, it is a free-flowing granular meal; used in a variety of ways in main meals and as a snack (West Africa)
<i>Garifoto</i>	Combination of gari and fish or egg sauce to make a one-dish meal (Ghana)
<i>Kokonte</i>	Dried, unfermented cassava chips, milled into flour and made into a thick paste; eaten with soups (Ghana)
<i>Kourou-kourou</i>	Thin gruel made by adding some fermented cassava flour to boiling water (Cameroon)
<i>Kumkum</i>	Cassava flour prepared from fermented tubers by grating, forming into balls, and drying over the fireplace; the dried balls are stored until required and marketed as balls or flour (Cameroon)
<i>Kpokpo gari</i>	Peeled and soaked tubers which are then grated, washed, dried, roasted into large hard grains and then soaked in water again; eaten with side dishes (Nigeria)
<i>Njambo</i>	Dried, fermented cassava chips, milled into flour and made into a thick paste (Gambia)
<i>Tapioca</i>	Wet or partially dried sieved starch particles heated with continuous stirring, forming gelatinized, dried granules; eaten as breakfast porridge (West Africa)
<i>Ugali</i>	Dried cassava chips produced by sun-drying, or steeped and fermented prior to drying, and then made into a thick paste; eaten with soup (Tanzania)
<i>Yakeyake</i>	Steamed cassava dough (Ghana)

Cassava flour is used in many bakery products, especially bread. Research into the use of cassava flour in bread has shown the process to be a viable technical proposition. Good quality breads have been produced with 10 to 100% of the wheat flour being substituted by cassava flour (see Figure 10.1) With regard to cakes and biscuits, 100% cassava flour can be used with good results. There is little information on the storability of these products, but it is known that they can be stored for up to 2 days.

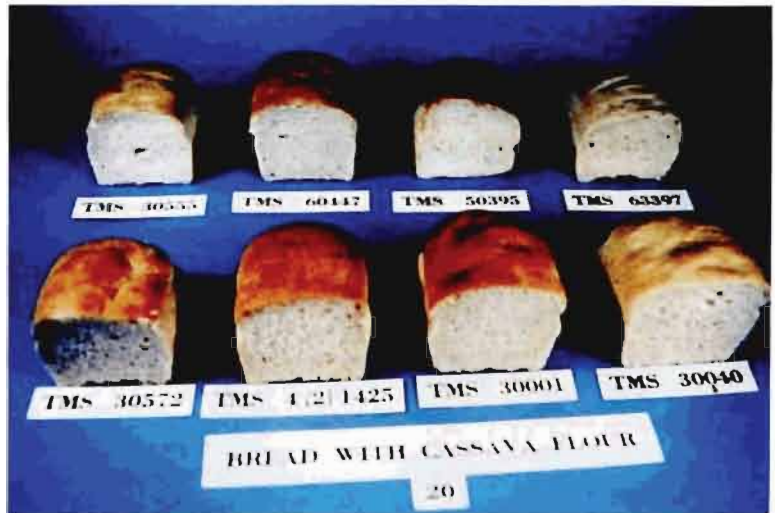

Figure 10.1
Bread with 20% cassava flour made from IITA improved varieties

Utilization for livestock feed

There is considerable potential for using cassava feed rations in local livestock industries (see Table 10.3). The production of cereals, especially maize, is not high enough to meet the energy requirements of both human beings and livestock. Since the 1960s, some EEC countries have used cassava chips in compound animal feed because of the high energy content and low price of cassava.

Research carried out by the Institute of Agricultural Research and Training in Nigeria has shown that substituting up to 44% of the maize in pig feed with cassava does not lead to any reduction in the performance of pigs. In fact, with the addition of 0.1 to 0.2% DL methionine, the performance of pigs fed on diets which contain more than 50% cassava meal is improved. It has also been reported that the use of cassava in the diet of white Fulani herds

Table 10.3

Animal feed rations using cassava meal

Cassava meal inclusion rates¹

Type of feed	Percentage cassava meal (dry)	
	<i>Cautious</i>	<i>maximum</i>
Broiler starter	5	10
Broiler finisher (4 weeks)	10	20
Chick' starter	5	10
Pullet grower	10	25
Layer	25	40
Sow/boars	10	30
Piglets (to 8 weeks)	5	10
Pigs (8-16 weeks)	10	25
Pigs (16 weeks-maturity)	15	30

Layers mash²

Cassava tuber meal	40.8
Cowpea*	20.0
Blood meal	16.8
Bone meal	2.5
Oyster shell	7.8
Salt	0.24
Min/vit mix (Pfizer)	0.24
	100.00

Notes: * Cowpea must be roasted before milling to remove antinutritional factors
Diet is not balanced for sulphoamino acids. Advisable to check acceptability to chickens

Source: ¹ Dr Tewe, University of Ibadan, Nigeria; ² Feed International, May/June 1980

in Nigeria has increased milk production by 22%; this has been accompanied by an increase in percentages of butter fat, protein and non-fat solids.

Utilization in industry

Cassava starch is an important industrial raw material. Over 100 cassava starch derivatives (chemically modified starch) have been developed to provide products with the physical and/or chemical properties required for specific applications. However, the capital investment needed for the production of starch derivatives is fairly high, and a careful economic analysis must be made before establishing an industry to produce these derivatives.

Raw, unmodified cassava starch can be used successfully, and in many instances advantageously, for industrial applications where, formerly, cheaply produced maize (USA and Canada) or potato (Europe) starches were used.

Cassava starch has wide applications in industry. It is used in the food industry in many preparations, including sauces, gravies, mustard powders, baby foods, tapioca products, glucose production, confectionery and bakery products; it is also used as a jelly or thickening agent. It is used extensively in the manufacture of adhesives, dextrans and pastes and as a filler in the manufacture of paints. In the textile industry, it is used for warp sizing, cloth and felt finishing.

Good quality cassava starch can be produced by cassava growers to meet standard specifications for the local market or export. This has been done in some developing countries, including India, Thailand and Malaysia. The important factors affecting the quality of starch are its color, uniformity of size, moisture content, purity and pH. The most desirable end-product should be a clean, white starch, free from specks, dirt and insect infestation, with a moisture content ranging from 12 to 18%.

Part IV

Research

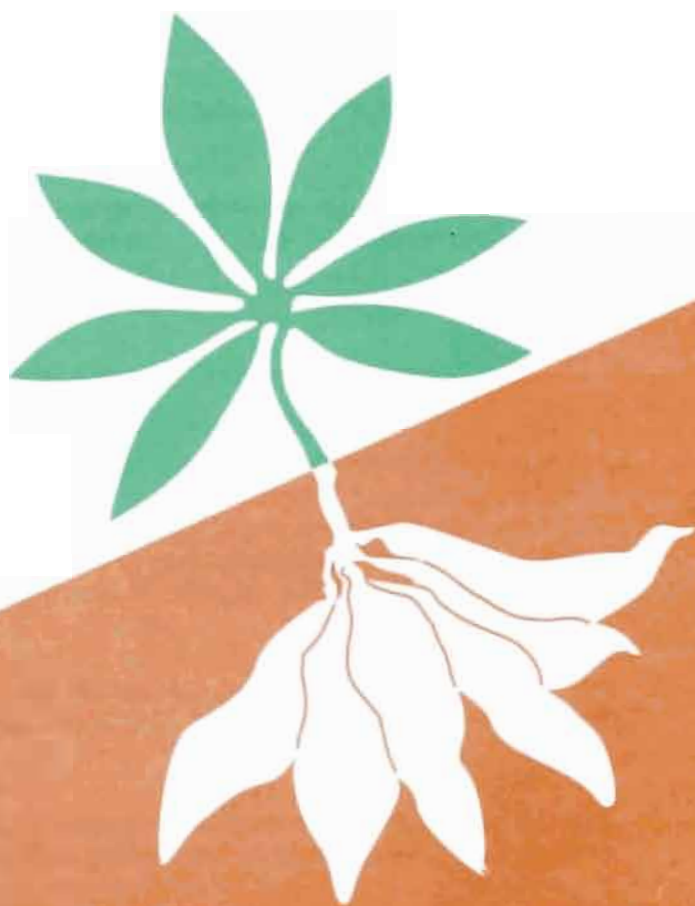

UNIT 11

Data Collection and Organization

In most field trials a number of treatments are involved. These treatments are assessed on the basis of some form of experimental design which allows 'analysis of variance' to be carried out; in other words, the experimental design provides the means for comparing the variation attributable to differences between the treatments with the unavoidable variation between plots (the error).

The most commonly used and simple experimental designs are Completely Randomized Design and Randomized Complete Block Design.

Completely Randomized Design

A simple field trial carried out to test the differences between four varieties of cassava — which will be called varieties A, B, C and D — is used here to illustrate the use of Completely Randomized Design. Some degree of replication of each treatment is essential to obtain an estimate of error, so assume that there are four replicates.

How should these 16 plots (4 varieties x 4 replications) be arranged in the field and how should the data collected from the plots be analyzed?

Unless the experimental site is absolutely uniform (which is never the case in practice), some form of random allocation of varieties or treatments to individual plots is necessary in order to avoid any systematic treatment bias. The simplest way to do this is to allocate all 16 plots completely at random to form a Completely

Randomized Design. An example of a Completely Randomized Design is shown below:

C	A	B	B
A	C	C	B
D	D	A	D
D	A	B	C

The form of the analysis of this design is to apportion the total 'variation' between the yields of the various plots into that part which can be attributed to *treatment effects* and a remaining *residual* part which gives an estimate of the 'variation due to sampling error'. Variation is measured in terms of variances (that is, Sums of Squares of Deviations, SS, divided by Degrees of Freedom).

An example of an 'analysis of variance' table for Completely Randomized Design (with hypothetical SSs and variances) is shown below in Table 11.1.

Table 11.1

Analysis of variance table for Completely Randomized Design

Sources of Variation (SV)	Degrees of Freedom (DF)	Sums of Squares of Deviations (SS)	Variance (or Mean Squares) (MS)
Total	15	100	
Treatments	3	40	13.33
Residual (or error)	12	60	5.00

Notes:

- 1 The DF for the total is 1 less than the total number of plots; that for treatments is 1 less than the number of treatments
- 2 For calculation of Total and Treatment SS, see page 127
- 3 Residual SS and DF are most easily calculated by differences; i.e. total minus treatment

The residual or error variance gives a measure of normal variation; the *square root* of this measure is termed the 'Standard Error (SE) of a single plot', which is an estimate of the standard deviation (SD) of individuals. Thus SEs of treatment means and SEs of differences between treatment means can be calculated, allowing a *t*-test to be carried out between a given pair of treatments. However, a prior step in testing significance is normally an overall test of all treatments by comparing the treatment variance with the error variance; this is termed the F test. (Details of these tests are discussed later in this unit.)

Randomized Complete Block Design

In practice, the Completely Randomized Design is used only when the experimental site is extremely uniform (for example, in a laboratory or greenhouse). Randomized Complete Block Design usually offers a considerable advantage over the Completely Randomized Design.

In Randomized Complete Block Design, the treatments are grouped into blocks (or replicates) containing 1 plot of each treatment arranged at random. For example:

Block I	B	A	C	D
Block II	C	A	D	B
Block III	D	C	B	A
Block IV	B	D	C	A

This Randomized Complete Block Design allows the effects of environmental differences between the blocks to be measured. Whereas in the Completely Randomized Design these effects remain part of the residual variation, in the Randomized Block Design the residual variation is decreased by the removal of these block effects. This usually leads to a lower error variance, lower SEs and a better chance of achieving significant differences between treatments.

Using the example which formed the basis of Table 11.1, the

analysis of variance table takes the following form (with hypothetical SSs and variances):

Table 11.2

Analysis of variance table for Randomized Complete Block Design

SV	DF	SS	MS
Total	15	100	
Treatments	3	40	13.33
Blocks	3	30	10.00
Error	9	30	3.33

Notes:

- 1 Block DF is 1 less than the number of blocks
- 2 Error DF and SS again calculated by difference
or
- 3 Error DF is the product of treatment DF and block DF

Example of analysis of variance for Randomized Complete Block Design

Three cassava varieties — N, E and F — are compared in a Randomized Complete Block Design with four replications. The layout of the plots and yield in kg/plot are as shown below.

	Block I			Block II		
Treatment	F	N	E	E	N	F
Tuber yield	359	330	372	340	288	337
	Block III			Block IV		
Treatment	F	N	E	E	F	N
Tuber yield	373	295	343	341	302	313

The objective is to carry out an analysis of variance to determine if these varieties are significantly different in yield.

Step 1

Form a two-way table of blocks x treatments and form the block and treatment totals and the 'grand total'.

Table 11.3

		Block I	Block II	Block III	Block IV	Treatment totals
Treatment	N	330	288	295	313	1226
Treatment	E	372	340	343	341	1396
Treatment	F	359	337	373	302	371
Block totals		1061	965	1011	956	3993*

Notes:

This overall total is termed the 'grand total'. When drawing up any two-way table, always check that the sum of the totals on each of the two sides is equal to this grand total.

Step 2

Calculate the Sum of Squares of Deviations. The Sum of Squares of Deviations for N individual x values is best calculated using the following formula:

$$Sx^2 = \frac{(Sx)^2}{N}$$

In this experiment, the basic x values are the weight of tubers per plot and the 'Total' Sum of Squares of Deviations for treatments or blocks is calculated thus:

$$\begin{aligned} \text{Total SS} &= 330^2 + 372^2 + 359^2 + 288^2 + \dots + 302^2 - \frac{(3993)^2}{12} \\ &= 1337535 - 1328671 = 8864 \end{aligned}$$

When these x values are grouped into treatment or block totals, the Sum of Squares of Deviations for treatments or blocks is calculated from these totals using a similar formula:

$$\frac{S(T)^2}{N_T} = \frac{(Sx)^2}{N}$$

where T represents each treatment or block total and N_T repre-

sents the number of x values which are added to form each appropriate total.

For this experiment the calculations are:

$$\begin{aligned}\text{Block SS} &= \frac{1061^2 + 965^2 + 1011^2 + 956^2}{3} - \frac{(3993)^2}{12} \\ &= 1331001 - 1328671 = 2330\end{aligned}$$

$$\begin{aligned}\text{Treatment SS} &= \frac{1226^2 + 1396^2 + 1371^2}{4} - \frac{(3993)^2}{12} \\ &= 1332883 - 1328671 = 4212\end{aligned}$$

Note that $\frac{(\sum x)^2}{N}$ occurs in all the calculations of Sum of Squares of Deviations, so in practice it is convenient to calculate this first. This term is usually called the Correction Factor (CF). Note also that although the second formula above uses *totals*, it does in fact give the Sum of Squares of Deviations of means from their *general mean*.

Finally, the 'Error' Sum of Squares of Deviations is calculated thus:

$$\begin{aligned}\text{Error SS} &= \text{Total SS} - \text{Block SS} - \text{Treatment SS} \\ &= 8864 - 2330 - 4212 = 2322\end{aligned}$$

Step 3

Calculate the Variances (or Mean Squares) by dividing the Sum of Squares of Deviations by the appropriate Degrees of Freedom:

$$\text{Block Variance} = \frac{2330}{3} = 776.66$$

$$\text{Treatment Variance} = \frac{4212}{2} = 2106.00$$

$$\text{Error Variance} = \frac{2322}{6} = 387.00$$

Step 4

Test for significant differences by means of an 'F test'. An 'F' value

(or Variance Ratio) for treatments is formed by dividing the Treatment Variance by the Error Variance:

$$F \text{ for Treatments} = \frac{2106.00}{387} = 5.44$$

If this F value is large, it means that the treatment differences are much larger than those attributable to normal variation (remember that the Error Variance is taken as an estimate of normal variation). The level of significance of an F value is determined by comparison with an F value from tables obtainable from any standard statistical textbook. These table values show that an F value derived from 2 Degrees of Freedom for treatments and 6 Degrees of Freedom for error must be at least equal to 5.14 to achieve 5% significance and 10.12 to achieve 1% significance. In this experiment, the calculated F value is 5.44, indicating that the treatment effects are significant at 5%.

It may also be of interest to test for significant differences between blocks. In this case, the calculated F value is 2.00 (see Table 11.4) and the tabulated value is 4.76 at 5%; therefore, there was no significant difference between blocks.

The complete analysis of variance table may now be drawn up:

Table 11.4

Complete analysis of variance table				
SV	DF	SS	MS	F
Total	11	8864		
Block	3	2330	776.66	2.00
Treatments	2	4212	2106.00	5.44*
Error	6	2322	387.00	

Step 5

Calculate a 'Least Significant Difference' (LSD) to determine which treatments are significantly different.

This part of the analysis is essentially a form of the simple *t*-test. In a *t*-test, a *t* value for two treatment means is calculated by expressing the actual difference between the means as a number of SEs. This is then compared with the tabulated *t* which indicates the least number of SEs necessary for significance. When compar-

ing a number of treatment means in an analysis of variance, however, it is usually more convenient to calculate the absolute difference which is necessary for significance; this is termed the Least Significant Difference. It is calculated by multiplying the SE of the difference between two means by the appropriate tabulated t value obtainable from any standard statistical textbook. The SE is based on the Error Variance because it is against some estimate of normal variation that treatment differences are being compared. Thus this SE can be written as:

$$\sqrt{\frac{\text{Error Variance (for mean A)}}{N} + \frac{\text{Error Variance (for mean B)}}{N}}$$

where N is the number of individual items of data contributing to the mean. Since, in a simple analysis of variance, N is the same for all treatment means, this SE can also be written as:

$$\sqrt{\frac{\text{Error Variance} \times 2}{N}}$$

and the LSD (at 5%):

$$\sqrt{\frac{\text{Error Variance} \times 2}{N}} \times t \text{ (at Error DF and at 5\%)}$$

For this experiment:

$$\text{LSD} = \sqrt{\frac{387.0 \times 2}{4}} \times 2.447 = 34.038\text{kg}$$

This is therefore the least difference which must occur between two treatments for them to be declared significant at 5%. (LSDs can also be calculated at 1% or 0.1%.)

Table 11.5

Comparison of treatment means and LSD				
	Treatments			LSD at 5%
	N	E	F	
Mean	306.5	349.0	342.7	34.04

Comparing treatment differences with the LSD, we conclude that the means of treatments E and F are significantly greater than for

N, but treatments E and F are not significantly different. In other words, varieties E and F significantly outyielded N (which may be a local check) but varieties E and F are not significantly different.

$$\begin{aligned}(E - N &= 349.0 - 306.5 &= 42.5 \text{ sig.}) \\(F - N &= 342.7 - 306.5 &= 36.2 \text{ sig.}) \\(E - F &= 349.0 - 342.7 &= 6.3 \text{ NS})\end{aligned}$$

Step 6

Calculate the Coefficient of Variation (CV). The CV simply expresses the SE of a single plot

$$\sqrt{\text{Error Variance}}$$

as a percentage of the general mean, thus giving a relative measure of the degree of variability within the data. A high CV represents a high degree of variability. Such variability is usually only partly the result of the inherent variability of the parameter being measured, because considerable variability can arise as a result of the way experiments are handled. Thus the CV helps to indicate the degree of accuracy with which an experiment has been conducted. For this experiment:

$$CV = \frac{\sqrt{\text{Error Variance}}}{\text{General mean}} \times 100\% = \frac{\sqrt{387.0}}{332.75} \times 100\% = 5.91\%$$

For yield trials of this sort, a CV of up to 15%, or even 20%, is acceptable, so this CV is good and indicates a high level of accuracy. It is important to note, however, that in this particular example the analysis of variance was carried out using the yield per plot. For better comparison, yield per plot is converted to yield per hectare before carrying out the analysis.

Some practical considerations in designing experiments

The following practical points should be borne in mind when designing an experiment.

Need to avoid bias

It is very important to avoid designing an experiment to test a preconceived opinion. For example, when carrying out a variety trial to test three varieties A, B and C, the experiment is biased in

favor of variety A if the person carrying out the experiment is convinced that variety A is superior.

Treatments

Include a large enough number of treatments to provide as much information as possible. For example, when carrying out a fertilizer experiment it is important to include a wide range of levels from minimum to maximum so as to reveal all possible effects. It is important to include a control treatment or check as the basis of comparisons (for example, a 'no fertilizer treatment' in the case of a fertilizer experiment, or a known variety or local check in the case of a variety trial experiment).

Record taking

It is essential to take records regularly throughout the duration of the experiment. This helps provide an account of the relative significance of each treatment. For example, one or two plots may be severely damaged by pests or diseases during the course of the experiment and, consequently, yield for the treatments concerned may be extremely low. If regular records are taken, it is possible to account for the low yields.

Plot size

Both the accuracy and the value of the results which are obtained from an experiment are influenced to a great extent by plot size. It is important to avoid using extremely small plots for field experiments because small plots tend to exaggerate the results and increase the error.

For example, an error of 5kg on a 0.05ha plot could easily convert to an error of 100kg per hectare. For this reason, the results which are obtained from a plot experiment are *never* expressed on a hectare basis. Experimental error diminishes as plot size increases, although this reduction is smaller when the plot size is greater than 0.025ha.

However, small plots are usually necessary when a large number of varieties are being tested (for example, in a breeding program when a large number clones are being evaluated). At IITA, a standard plot for Uniform Yield Trial for Cassava consists of four rows of 10m each. The central two rows are harvested for yield

estimates and converted to yield per hectare. In general, the following factors influence the size of the plots used:

- type of crop (this influences the spacing and, therefore, the size of the plot; it is common practice to use relatively larger plots for cassava)
- number of treatments (the larger the number of treatments involved, the smaller the plot size)
- type of machinery used in planting, weeding and harvesting
- land area available for experiment
- labor and funds available for the field trial

Plot shapes

It is important to select plot shapes that minimize both the effects of soil fertility differences and border effects. Where there are large differences in soil fertility, long narrow plots are probably the best compromise when plots are laid along the contours. Fertility drift is usually at right angles to the contours. If the land and soil fertility are reasonably uniform, square plots are usually preferred because these types of plots have the shortest perimeter and therefore the smallest discards for a given area. For example:

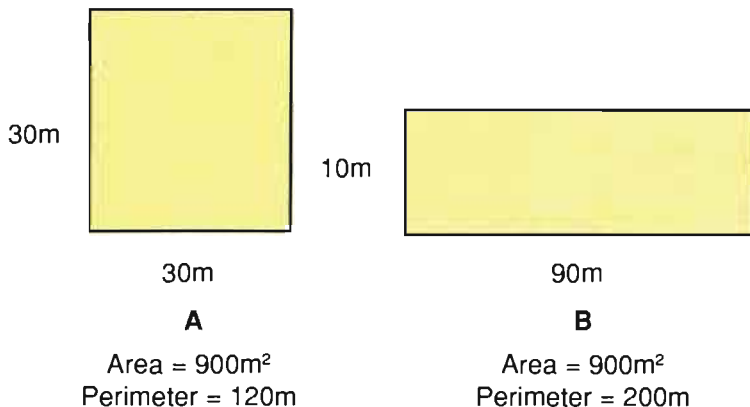

Square plots tend to minimize border effects. In practice, however, there are always discard rows to reduce error resulting from border effects.

Interplot competition

Competition often occurs between adjacent rows of different treatments and this may lead to serious errors in variety trials. This is particularly likely to occur where the varieties involved differ markedly in their growth habits. For example, interplot competition may raise the yield of a vigorous variety and lower the yield of a less vigorous one when they are planted in neighboring plots. Where interplot competition is expected, the effect can be minimized by using wider alleys.

In spraying and dusting experiments, it is also vital to consider the effects of drifting chemicals. This can be minimized by the use of so-called 'drift rows' between treatment plots.

Intra-plot competition

Intra-plot competition arises as a result of uneven distribution of plants within each plot (rectangularity effects). In other words, for the same number of plants per plot, it is possible to have different distribution patterns which lead to differing levels of competition, resulting in serious error in yield estimates.

Similarly, differences in the stands or number of plants per plot could lead to serious errors. Thus it is usually important to try to achieve a uniform stand in any variety trial experiment.

Randomization

Experimental conditions are rarely uniform except in laboratories or greenhouses. Random allocation of treatments is essential to minimize the effects of unknown factors. This reduces the bias which may be introduced in the results. It is important to have a separate randomization for every experiment. Avoid using the same randomization for several seasons or experiments because this will destroy the value and applicability of the results.

Replication

Differences in soil fertility in the experimental field are a major source of error. The most practical way to reduce error resulting from differences in soil fertility is to replicate the treatments. Replications provide an estimate of the magnitude of the error and

reduce the error, thereby increasing the applicability of the results. The number of replications required in any given experiment depends to a large extent on the variability of the test material and to some extent on the cost of labor involved in maintaining the experiment.

Generally, it is better to use more than four or five replications in a field trial. The rule of thumb is to provide for not less than 10 DF for the error term.

Local control

This refers to the grouping of treatments into blocks. It allows for the elimination of a certain proportion of the total variation which is irrelevant in making comparisons.

In simple experiments, each block or replicate contains the same number of treatments distributed at random. Thus the experimental error is reduced because variation between plot yields can be partly attributed to a measurable amount caused by block differences. This leads to a lower Error Variance, lower SEs and a better chance of achieving significance.

Standard scoring system for major diseases, pests and agronomic characteristics

The Root, Tuber and Plantain Improvement Program at IITA conducts research on cassava, yam and plantain. The overall objective of the program is to develop varieties which have high stable yields and resistance to the major diseases and pests, and are suitable for the main types of utilization.

The elite materials from IITA are tested by the national agricultural research systems (NARS) under conditions like those in which the materials will eventually be cultivated by farmers. In order to ensure that information received from NARS is useful for further improvement, it is important that a standard procedure for record taking and scoring is developed and adopted by the collaborating scientists.

This section provides some information on record taking and scoring for the major diseases, pests and agronomic characteristics used in a cassava breeding program. During the growing

season, data should be recorded on data sheet similar to the one shown below in Figure 11.1.

Filename:		Experiment Name:												Page: -										
LOCATION:		DATE PLANTED				DATE HARVESTED				RESEARCHER														
		REP:																						
PLOT	CLONES	PLTS	CMV	CMV	CBB	CMV	CBB	CAD	RS	CGM	CMV	PLTS	YIELD	TUBERS	TUBER	TUBER	TUBER	HCN	DRY	GARI	GARI	POUND		
		GERM	MAP	MAP	MAP	MAP	MAP					HARV		SIZE	SHAPE	LENGTH	MATT	RATE	QUALITY	ABILITY				

Figure 11.1
Record sheet used in a cassava breeding program

Diseases

The major diseases of cassava are ACMV, CBB and CAD.

Cassava mosaic virus. Leaves are reduced in size, misshapen and twisted, with chlorotic areas separated by green areas. Leaflets may show a nearly uniform mosaic pattern.

Scoring for ACMV is done at 1, 3 and 6 months after planting, using the following scoring system:

- 1 = no symptoms observed

- 2 = mild chlorotic pattern on entire leaflets or mild distortion at base of leaflets, rest of leaflets appearing green and healthy
- 3 = strong mosaic pattern on entire leaf, and narrowing and distortion of lower one-third of leaflets
- 4 = severe mosaic, distortion of two-thirds of leaflets and general reduction of leaf size
- 5 = severe mosaic, distortion of four-fifths or more of leaflets, twisted and misshapen leaves

Cassava bacterial blight. The manifestation of the severity of CBB depends on plant age and time of evaluation. Thus, scoring is done once during the peak of the rainy season and once at the end of the rainy season, using the following scoring system:

- 1 = no symptoms
- 2 = only angular leaf spotting
- 3 = exclusive leaf blight, leaf wilt and defoliation, and gum exudation on stems and petioles
- 4 = extensive leaf blight, wilt, defoliation and stem die-back
- 5 = complete defoliation and stem die-back; stunting and die-back of lateral shoots

Cassava anthracnose disease. CAD is characterized by light to dark brown oval lesions on the soft green stems and at leaf axils; the lesions on the axils lead to petiole epinasty, petiole necrosis, wilting, and defoliation. On older plants, pale brown, shallow depressions appear on the stems and, as the stem becomes woody, develop into deep cankers. The following scoring system is used:

- 1 = no symptoms
- 2 = few shallow cankers on woody stems, late in the growing season
- 3 = many deep cankers on woody stems followed by distortion
- 4 = many oval lesions on green stems
- 5 = many lesions on green stems and severe necrosis at leaf axils, followed by wilting and severe defoliation

Pests

The major pests affecting cassava are CGM and CM.

Cassava green mite. This dry-season pest attacks the young portion of the shoot. Initially, yellowish (chlorotic) 'pinpricks' appear on the surface of newly formed leaves. Symptoms vary from a few chlorotic spots to complete chlorosis. Heavily attacked leaves are stunted and deformed, and severe attacks cause terminal leaves to die and drop, producing a 'candlestick' appearance. Scoring is best done at the two transition periods (the rainy/dry season transition and dry/rainy season transition), using the following scoring system:

- 1 = no obvious symptoms
- 2 = moderate damage, no reduction in leaf size, scattered chlorotic spots on young leaves
- 3 = severe chlorotic symptoms, slight reduction in leaf size
- 4 = severe chlorotic symptoms and leaf size of young shoot severely reduced
- 5 = very severe chlorosis and significant reduction in leaf size and young shoot portion; extensive defoliation; candlestick appearance of young shoots

Cassava mealybug. CM is also a dry-season pest. The terminal shoots of damaged plants become stunted and deformed. Internode length is reduced, causing twisted stems. Severe attack leads to death, starting at the plant tip. Scoring is done at the peak of the dry season, using the following scoring system:

- 1 = no obvious symptoms
- 2 = slight bunch top appearance, and slight reduction in leaf size and internode length
- 3 = moderate bunch top symptoms, and serious reduction in leaf size and internode length
- 4 = severe bunch top symptoms; obvious reduction of internode length and severe reduction in leaf size and leaf area
- 5 = candlestick appearance; internode length reduced, young portion of shoot curved and completely defoliated

Agronomic characteristics

The main agronomic characteristics to be scored are tuber size, tuber shape, neck length, skin color, lodging and flowering.

Tuber size. The scoring system used for tuber size is:

- 1 = very small (less than 0.5kg)
- 2 = small (0.5 to 1kg)
- 3 = medium (1 to 2kg)
- 4 = large (2 to 5kg)
- 5 = extra large (more than 5kg)

Tuber shape. The scoring system used for tuber shape is:

- 1 = round
- 2 = oval
- 3 = medium, long
- 4 = fat, long
- 5 = thin, very long

Neck length. The scoring system used for neck length is:

- 1 = short or no neck
- 2 = about 5 to 7cm long
- 3 = about 7 to 10cm long
- 4 = about 10 to 15cm long
- 5 = over 15cm long

Skin color. The scoring system for skin color is:

- 1 = white
- 2 = light brown
- 3 = dark brown

Lodging. Record the number of plants lodged at an angle of more than 45°.

Flowering. Record the number of days (not dates) from planting to the time when 50% of the seedlings flowered.

UNIT 12

On-Farm Research

The objective of on-farm research (OFR) is to identify, in co-operation with farmers, improved farming practices which are adaptable to farmer conditions and will raise productivity in a sustained way. With the farmer as a research partner, new technologies are tested under farmers' conditions; their acceptability and profitability is closely monitored; what is not appropriate is rejected; what is modifiable is modified; and, in the light of results obtained, new technologies are incorporated. In other words, OFR is a continuous process, with each phase built upon the experiences of previous phases.

For new technology to be adopted by farmers, it must solve some of their constraints without creating new ones of the same magnitude or it must tap some of their unused, readily available resources. An adequate choice of technologies therefore requires good knowledge of farmers' conditions and of the farming system they practise.

The farm as a system

A system is an orderly arrangement of parts which are performing various functions to achieve an overall objective. A farming system emerges as the result of the decisions made to devote a set of resources to a set of activities in order to meet the requirements of the farm family.

There are two dimensions to the farming system environment — material and human. The material environment consists of physical elements (such as precipitation, temperature, topography, solar radiation and soil) and biological elements (such as natural vegetation, and plant and animal pests and diseases). These physical and biological elements determine what type of crops

can be grown in a particular area, given a suitable human environment.

The human environment consists of economic, institutional and social elements. Economic elements include the economic policy of the country or region. This policy determines quantities, absolute and relative prices of inputs and outputs, and the physical infrastructure (such as transportation, water supply, health services, and marketing, processing and storage facilities). Institutional elements include the laws of the area, credit and marketing conditions, contractual arrangements, extension services, property rights to land, water, trees and pasture, seed distribution, quality control of inputs and outputs, grading and measuring systems, educational institutions and taxation. The social elements include the culture and customs of a community.

On-farm research process

Research under farmers' conditions starts with the collection of data on the farming system and its environment. This includes a study of existing sources of information, the gathering of secondary data and an informal exploratory survey.

The purpose is to analyze the system's major material and human elements, to understand the goals of the farmer, to determine the major factors that influence his/her decisions, and to describe the resource flows and how they relate to each other (see Figure 12.1)

Monitoring the degree of adoption (the only valid proof of success) is part of the OFR process. Education for mass adoption, however, is an extension activity beyond the scope of OFR, although pre-extension tests which validate a technical package and guarantee its readiness for mass adoption are a component of OFR.

In essence, OFR embraces:

1. Choice of research area
2. Initial collection of data through exploratory surveys and the study of existing secondary information
3. Choice or design of new technologies for testing
4. On-farm testing and evaluation, including monitoring of adoption
5. Special studies

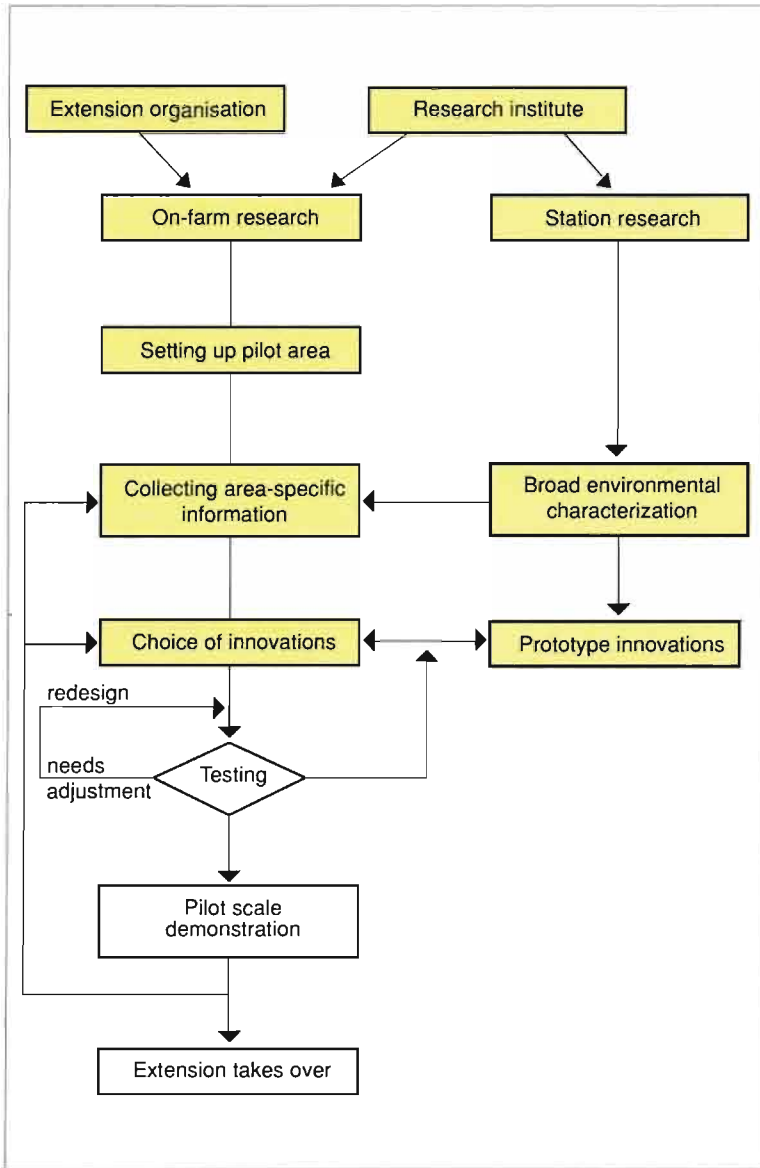

Figure 12.1
Flowchart of OFR activities and their interrelationships

The on-farm research team

The OFR team comprises scientists, field assistants and extension agents. It is recommended that the core includes at least two experienced research officers — an agronomist and an agricultural economist — and that the field assistants should have

received training in implementing trials and collecting agronomic and economic data. The field team is headed by a junior researcher, perhaps a first-degree holder. Researchers in other disciplines (from the team's institution or from other institutions, such as universities) are invited to participate when needed; for example, soil scientists and sociologists can provide crucial input for the exploratory survey and design of trials.

The team, by the nature of its work, enters an area that has traditionally been served by the extension service. Tasks overlap; the extension agents have much to offer the team as a result of their experience in the area, and will ultimately be responsible for disseminating successful technologies deriving from the team's work. It is therefore important to have one or two local extension agents associated with the field team to participate in such activities as the exploratory survey, trial design, supervision, monitoring and farmers' field days.

The target area and the pilot research area

Because of the intensive nature of OFR, the area chosen by the field team must be manageable and it must be representative of a larger area. This is sometimes called the 'extrapolation' or the 'target area' for which the research results are relevant (see Figure 12.2).

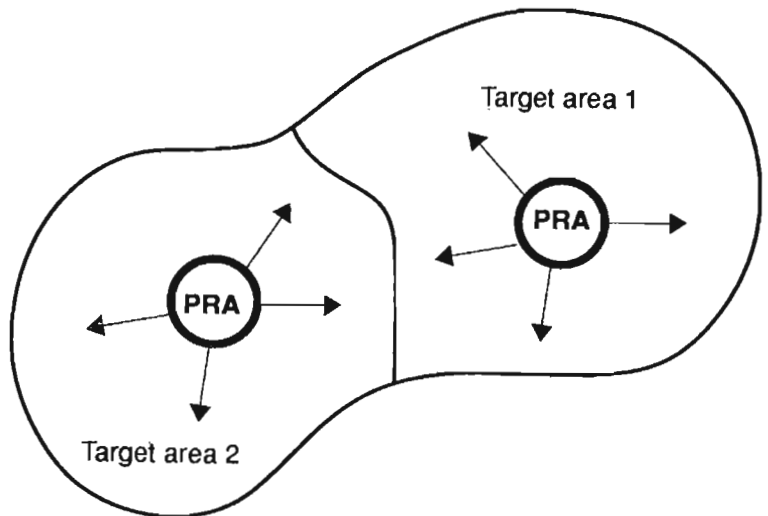

Figure 12.2

*Target areas with their representative pilot research area (PRA)
Arrows indicate assumed applicability of the results*

Choice of the target area. The choice of a target area for OFR should reflect:

- the research institute's mandate (the crop, region or ecological area that is the focus of the institute's activities)
- the government's development priorities (for example, 'problem areas' or 'high-potential areas')
- the need for a single homogeneous ecological zone (that is, with minor differences in climate, soil associations and vegetation) where differences in population density, ethnic groups or farming systems are minor

In choosing the target area, soil maps, climatic charts and other geographical documents are studied and a reconnaissance tour is conducted.

Choice of a representative pilot area. In conventional multi-location and demonstration trials, the experimental sites are distributed across the target area. Because of the intensive nature of OFR, one or a few compact pilot areas that can be considered as a model for the whole target area are chosen. A pilot area should:

- incorporate all the microvariability of the target area, such as differences in access and distance to roads and markets, small-scale soil variations and population density
- be manageable during the testing phase (not more than 10-15km can be traveled daily by field staff on bicycles or motorbikes and acceptable living quarters must be available for field assistants)
- be close enough to the research station to enable the scientists to visit it frequently to monitor the on-farm tests

Collecting initial information on the research area

Initial information is collected to provide a basis for defining research priorities. Data collection is carried out in two phases:

1. an analysis of the existing base data
2. an exploratory survey

The findings are then analyzed and a report is written.

Base data. The following sources may provide valuable base data:

- meteorology bulletins or records
- soil and relief maps
- publications of the national statistical bureau
- regional project reports
- local government offices
- university students' village studies
- written or verbal information from extension services, agro-services centers and special interest groups such as missionaries

The base data are analyzed and a preliminary report is prepared, using the formula recommended for the final version (see Table 12.1). This serves as the framework to which the results of the exploratory survey are added.

Table 12.1

Suggested contents of the report on the pilot research area

General features of the area	Maps, administrative divisions, area, population, settlement pattern, ethnic groups, traditional hierarchy, religions
Physical and biological environment	<p><i>Climate</i> Evapotranspiration, rainfall regime, median and quartiles of rainfall, critical periods, temperature, humidity</p> <p><i>Vegetation</i></p> <p><i>Land, soil and water</i> Land form, land types and associated soils with frequency of occurrence, texture and color of topsoil, soil depth, hardpans, water table heights, water storage capacity, chemical fertility</p>
Human environment and physical infrastructure	<p><i>Economic environment</i> Imports of capital goods, foodstuffs, agricultural exports, exchange rate policy, employment opportunities, urban migration</p> <p><i>Institutional environment</i> Credit facilities, input supply services, extension services, marketing facilities, farmers' organizations</p>

	<p><i>Social environment</i> Land tenure, labor distribution by gender, community help, festivities</p> <p><i>Physical infrastructure</i> Road conditions, availability of transport, markets, large-scale storage, schools, water supply, electricity, medical services</p>
Farming systems	<p><i>Cropping patterns and land use</i> Crops, cropping patterns and crop associations, cropping patterns and fertility, utilization of land types, fallow, products collected from the bush</p> <p><i>Crop varieties</i> Characteristics of varieties</p> <p><i>Cropping operations and crop calendar</i> Land preparation, planting, crop densities, weeding, manuring, harvesting and cropping</p> <p><i>Inputs and yields</i> Source of seed and planting material, use of fertilizer and agro-chemicals, tools, crop yields</p> <p><i>Crop disorders</i> Pests, diseases, weeds and their control, nutrient deficiencies</p> <p><i>Postharvest activities and consumption</i> Storage, processing, marketing, prices of farm products, nutritional habits, consumption</p> <p><i>Livestock</i></p>
Factors of production	<p><i>Land</i> Ownership and access to land, farm sizes</p> <p><i>Capital, capital goods and capital formation</i> Cash sources and use, input purchases and cost, cash flow, investment</p> <p><i>Labor</i> Labor profile, division of labor, sources and cost of labor</p> <p><i>Management and information</i> Educational level, farm management systems</p> <p><i>Decision-making and production choices</i> Gender roles in decision-making, production choices (food, cash crops, livestock, non-farming activities)</p>
Analysis of farmers' conditions	<p><i>Typology of farms and fields</i></p> <p><i>Constraints and opportunities</i></p>

Exploratory survey. Through the exploratory survey, the team aims to establish an understanding of the system and its constraints and potential in an intensive, informal way, combining field observations and farmer interviews. Most of the time is spent visiting farmers' fields, but these visits are preceded and followed by a group meeting with farmers in the village.

Formal questionnaires are avoided during field visits but a checklist is used to keep track of the topics that have not been covered (see Table 12.2). For recording physical information on individual fields, a simple data sheet is completed in the field. Field notebooks, soil augers, magnifying glasses, and sample bags for plants and soil are carried (see Mutsaers et al., 1986)

Table 12.2

Checklist of information to be collected during the field survey

	Field visit	Group discussion
General features of the area		
Ethnic groups, traditional hierarchy, religions		x
Physical and biological environment		
<i>Climate</i>		
Farmers' perception of rainfall and consequences for cropping	x	x
<i>Vegetation</i>		
Vegetation type (data sheet)		
<i>Land, soil and water</i>		
Land form, land types, soils (data sheet)		
Soil fertility	x	
Seasonal availability of water		x
Human environment		
<i>Economic environment</i>		
Availability and origin of items not produced locally (market visits)		
Urban migration		x
<i>Institutional environment and services</i>		
Availability and prices of capital goods, inputs (ask traders, distribution centers, etc.)		
Availability and organization of credit		x

	Field visit	Group discussion
Access to extension and input delivery systems		x
Farmers' organizations		x
<i>Social environment</i>		
Access to land and tenurial arrangements	x	x
Division of labor by age and gender		x
Health conditions	x	
Festivities		x
<i>Physical infrastructure</i>		
Accessibility, availability of transport		x
Location, frequency, role of markets		x
Large-scale storage facilities		x
Schools, water supply, electricity, medical services	x	
The farming system		
<i>Cropping patterns and land use</i>		
Crops, cropping patterns, crop associations	x	x
Differences in cropping pattern among fields/land types; reasons	x	
Ownership of crops within same field	x	
Criteria for choosing/abandoning field	x	
Duration and utilization of fallow	x	x
Products collected from the bush		x
Obsolete, new crops; reasons		x
Other changes in farming practices over past 40 years (ask old people)		x
<i>Crop varieties</i>		
Crop varieties and their characteristics	x	
<i>Cropping operations and crop calendar</i>		
Plant spacing and arrangement	x	
Time and method of land preparation, planting, weeding, harvesting	x	
<i>Inputs and yield</i>		
Sources and maintenance of seeds/planting material	x	
Use of organic, inorganic fertilizers, household refuse, agro-chemicals	x	x
Farm implements	x	
Estimates of yields	x	
<i>Crop disorders</i>		
Weeds, time and method of control	x	
Pests and diseases and their control	x	
Nutrient deficiencies	x	
<i>Postharvest activities and consumption</i>		
Storage facilities (household and community)	x	

	Field visit	Group discussion
Utilization of crops, proportions marketed and consumed	x	
Processing of crops and food by the farm household or community	x	
Prices of farm products	x	x
Consumption patterns and food preferences; types of purchased food		x
Water and fuel requirements and sources		x
Utilization of crop residues and by-products	x	
<i>Livestock</i>		
Livestock systems, species, husbandry, feeding pattern, interaction with cropping	x	x
Factors of production		
<i>Land</i>		
Availability of land	x	x
Number, size and location of fields per household	x	
Accessibility of fields	x	
<i>Capital, capital goods and capital formation</i>		
Sources and principal usages of cash	x	
<i>Labor</i>		
Sources and cost of labor, family and hired	x	
Distribution of labor, peaks, slack periods and bottlenecks	x	x
<i>Management and information</i>		
Educational level of farmers	x	
<i>Decision-making and production choices</i>		
Gender roles in these processes		x

Analysis of farmers' conditions. Immediately after the survey, the findings are analyzed in a few round-up meetings. The core features of this analysis are:

- a typology of farms and field: classification of the farms and fields according to criteria appropriate to the aim of the OFR (for example, size, or degree of market orientation)
- an identification of constraints and opportunities: listing elements in the farming system and the environment that limit productivity and for which solutions may be sought, and describing features of the system which may be better exploited to increase productivity

Writing the report. After an analysis has been made of the farmers' conditions, a draft report is completed before the on-farm trials are designed. The report begins with a brief description of the location of the area and its size; administrative divisions; patterns of population settlement; and ethnic groups, traditional hierarchy and religions.

The report should also include a description of:

- the physical and biological environment (climate, vegetation, land, soil and water)
- the human environment and physical infrastructure (the economic, institutional and social environment, and physical infrastructure)
- farming systems (cropping patterns and land use, crop varieties, cropping operations and crop calendar, inputs and yields, crop disorders, postharvest activities and consumption, and livestock)

On-farm experimentation

Choice of technologies. From analysis of the existing base data and exploratory survey data, the constraints (those elements in the farming systems and their environment that limit the systems' productivity) are carefully examined. Opportunities (features of the system that may be better exploited to increase productivity and farmers' welfare) are also examined.

The next step is consider whether a particular technology is available or can be developed to alleviate a constraint or exploit an opportunity. This technology could be a new crop or cropping pattern, a fertilizer, a new variety, a labor-saving machine (for example, in field preparation or crop processing) or a crop protection chemical.

Inevitably, there are some constraints and opportunities which, in terms of the OFR team's mandate and time schedule, cannot be addressed. The addressable constraints or opportunities are those for which solutions can be sought in on-farm trials in the season following the exploratory survey. They are arranged in order of priority, and the technologies which are appropriate to each one are considered. The criteria determining which technologies are considered may be divided into necessary criteria and desirable criteria.

Necessary criteria

- the technology should address constraints or exploit opportunities that actually exist in the localities in which it is to be tested
- the technology should be simple enough to be demonstrated by trained extension personnel and operated by the target farmers
- the technology should be economically viable in terms of the yield levels farmers may be expected to achieve and prices and costs prevailing in the villages

Desirable criteria

- the seasonal labor requirements of the new technology should complement, rather than compete with, the labor requirements of other farm operations
- the technology should require no resources or inputs (capital outlay, expert maintenance or service facilities) that are not available to the target farmers
- the technology should not be more vulnerable to weather, pests, diseases or other risk factors than is the case with the existing production practices, and should be compatible with the prevailing livestock-herding conventions

Design of on-farm trials

The word 'design' in the context of on-farm trials is used broadly to mean:

- the choice of representative villages and farms for siting of trials
- the selection of treatments to be compared in the trials
- the choice of the number of replicates and of the distribution of these replicates within and between farms
- the choice of the most appropriate experimental design
- the size of plot (in the statistical sense) to be used

Types of on-farm trials

On-farm trials can be grouped according to:

1. The type of innovations being tested:
 - improvement of crops and cropping techniques in existing cropping patterns
 - improved or new cropping patterns and new crops
 - soil, vegetation, and water-management practices
2. The state of knowledge:
 - exploratory trials
 - verification trials
 - pre-extension trials
3. The degree of farmer involvement;
 - researcher-managed, researcher-executed
 - researcher-managed, farmer-executed
 - farmer-managed, farmer-executed

On-farm experimentation with cassava

This section outlines the methodology for conducting on-farm experiments once the preparations described above have been completed. Examples from a case study of the Ohosu area in Nigeria are used to illustrate the on-farm experimentation concept.

Diagnostic survey

It is important to provide clear objectives to guide the team of scientists (biological and social) in drawing up questionnaires designed to provide answers to the objectives of the study. Usually, these objectives are:

- to understand the resource base of cassava farmers
- to ascertain the importance of cassava in the welfare of the farmers
- to determine the cassava varieties grown and their sources
- to understand the cropping systems in the area
- to ascertain the labor available and its distribution between sexes, and between adults and children
- to identify the constraints to cassava production

In the Ohosu study, the objectives were:

- to determine the extent of adoption of improved cassava varieties in the specific location
- to measure the relative yields of traditional and improved varieties obtained by small-scale farmers
- to identify the factors that might be impeding the realization of the yield potential of improved cassava varieties adopted by the small-scale farmers
- to identify any potentially undesirable or adverse effects of the expansion of cassava production in the area
- to design field trials to address the constraints

Methodology

In the Ohosu study, the methodology used involved:

- site selection
- description of the physical characteristics and cropping patterns of the selected area
- study of the history of the spread of improved varieties into the area
- determination of the relative importance of improved and local cassava varieties in the farming systems
- measurement of the yields of local and improved varieties
- calculation of economic returns from the adoption of the improved cassava varieties by the farmers

Information which was not expected to vary significantly from farmer to farmer was obtained by using a group interview questionnaire. Information expected to vary significantly from farmer to farmer was obtained by using individual questionnaires. (See Figures 12.6 and 12.7, at end of unit).

Three villages in the Ohosu area were selected for study. In each village, 15 farmers were chosen by a random method from a list of farmers compiled by the community head. Questionnaires were

given to the selected farmers. The fields belonging to these farmers which were planted to cassava were measured. In addition, 40m² plots were harvested to determine farmers' yield and plant density; and soil samples in the 0 to 15cm layer were taken from four locations within the 40m², composited, and analyzed for physical and chemical characteristics using standard methods.

Analysis and interpretation of diagnostic data

The data collected was analyzed to provide information on:

1. Biophysical features:

- vegetation
- soil (physical and chemical properties)
- topography
- climate (rainfall, light and temperature)
- cassava yield
- diseases and pests
- cropping systems

Examples of rainfall and evapotranspiration for Ibadan, Nigeria, are given in Figure 12.3. Examples of major cassava-based systems and associated mean rainfall distribution for the Ohosu area are given in Figure 12.4 (*see overleaf*).

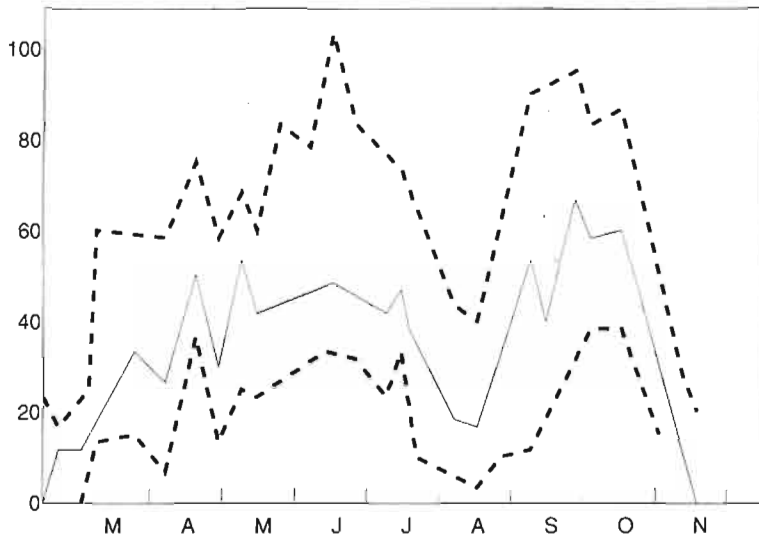

Figure 12.3

Rainfall and evapotranspiration at Ibadan, Nigeria, 1953-1973

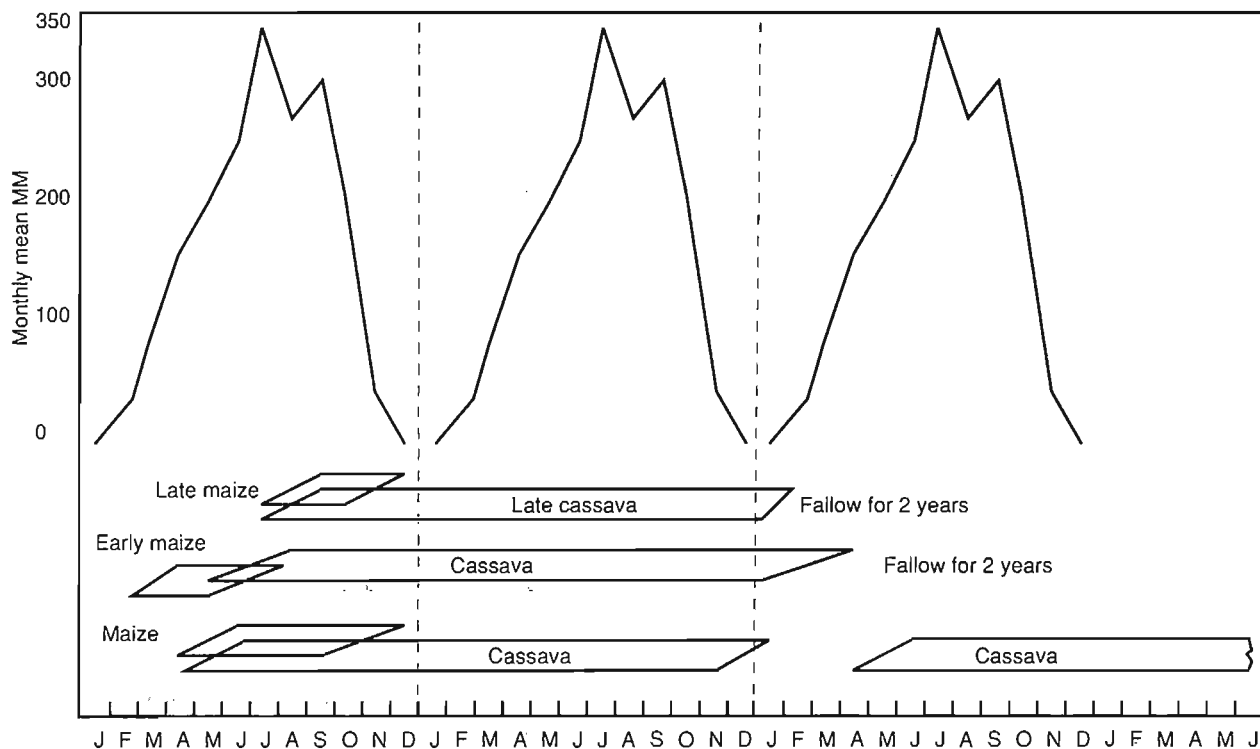

Figure 12.4
*The major cassava-based systems
 and associated mean rainfall distribution
 in Ohosu area, Bendel State, Nigeria*

2. Socioeconomic features:

farm factors: farm and non-farm enterprises, farm size, yield, farm labor, farm inputs. Figure 12.5 illustrates labor for farm operations. The peak labor demand period is from April to June. Any technology requiring additional labor may not be easily adopted during this period.

household factors: size of household, composition, religion, income, tribal origin, ages, sexes, social standing, secondary occupation

infrastructural factors: absence or presence of such facilities as adequate transportation, health services, water, industries, credit and extension services

market factors: volume of market, condition of end product and packaging, effect of substitutes

policy factors: pricing policy, input prices compared to cost of production, extension policy and research policy

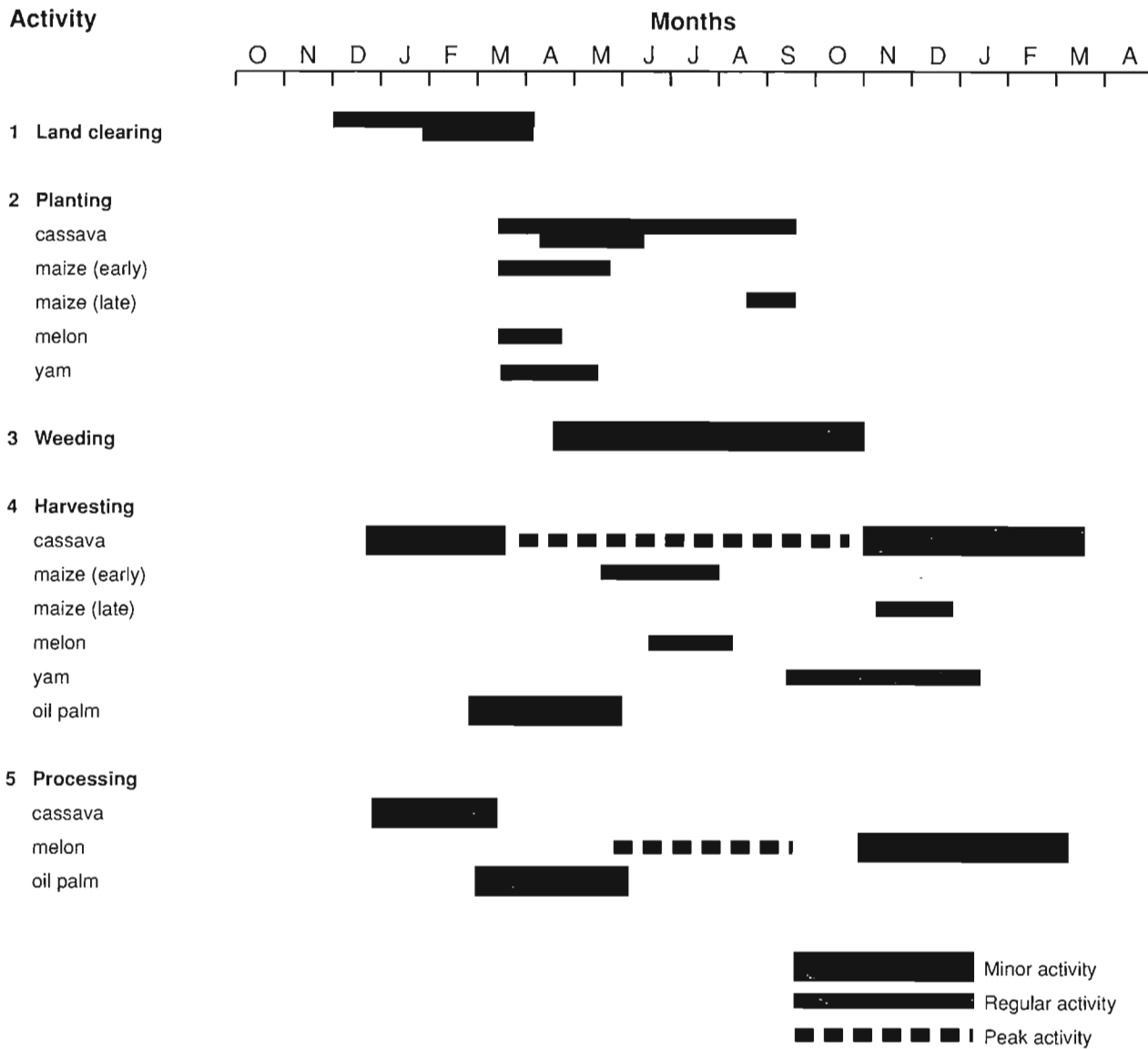

Figure 12.5.
*Calendar of farm operations indicating peak periods in the Ohosu area,
 Bendel State, Nigeria*

Constraints identified from diagnostic data

The main constraints identified from a village in the Ohosu study were:

- rapid decline of soil fertility after first year of cassava following a 3-year fallow
- acute weed infestation and decline in yields
- 80% of the farmers still planted an unimproved variety
- 95% of the population ate cassava in at least two meals a day, based upon 24-hour recall period; malnourishment and protein deficiencies were acute problems
- major pests were CM and CGM
- intercropping cassava with green maize and melon was common, with maize spaced at suboptimum populations
- most farmers had never been visited by an extension agent, did not use fertilizers and, because of processing problems, stored 70% of their cassava in the ground

Identifying researchable issues

The constraints are then listed in order of priority and those for which technologies are available for immediate on-farm research are identified.

If, for example, the constraint relating to malnourishment and protein deficiencies is selected as a priority for attention, it might be decided that the most effective way to address this problem is to introduce soybean into the farming system. The OFR approach would be divided into three stages:

1. introducing many improved soybean varieties into the cassava system by first testing them under researchers' control or on-station (see Figure 12.8, at end of unit); this includes exposing farmers to production problems through field days and obtaining their reactions
2. identifying one or two acceptable varieties and working with a team of nutritionists and food technologists to introduce soybean processing and utilization methods to farmers

3. conducting researcher-managed trials in the fields of a few farmers using acceptable soybean varieties; and popularizing soybean utilization

Designing on-farm research

In researcher-managed trials, farmer involvement is minimal. The researcher simply uses the farmer's field to conduct a trial. The location of the trial may enable the farmer to observe the differences between treatments and perhaps facilitates farmer adoption of new technologies.

An example of a typical researcher-managed trial is given here.

Researcher-managed trial

Title: Cassava/soybean intercropping at farm level

Objectives: To evaluate two varieties of soybean in cassava-based systems at farm level, and to assess farmer reaction to soybean as food

Number of farmers = 6

Replications/farm = 2

(Treatment description): Two soybean varieties intercropped with TMS 30572 cassava vs TMS 30572 cassava as sole crop

Thus:

Cropping systems = 2 (sole vs intercropped)

Soybean varieties = 2

Total number of plots = 8 per farm

Exercise:

1. Identify relevant data to collect in this trial
2. Prepare a data collection schedule
3. Note especially farmers' reactions to these trials during field days

Having identified the appropriate soybean variety, ascertained its compatibility with cassava, assessed the reactions of the farmers and introduced utilization methods to the farmers, the next stage involves the introduction of soybean into the farmers' cassava-based system.

This trial is made as simple as possible and managed by the farmers, as shown in the example provided here.

Farmer-managed on-farm trial

Treatment factors	Level
Cassava variety	2
Soybean variety	2
Management:	
Population	} Farmers
Pattern of planting	
Weeding, etc	

Costs

In this trial, the risk is minimal. Soybean varieties are simply being introduced into the cassava system and other trials have demonstrated that soybean in association with cassava does not reduce cassava yield and that soybean is compatible with cassava as an intercrop. The farmer is most likely to benefit.

Setting up the on-farm trial

Identify up to 30 project farmers whose fields are within the study area. With other OFR team members (such as subject-matter specialists) hold group meetings with the farmers to:

- discuss the treatments with them, including rationale for choice (*see* Table 12.3)
- make modifications based on farmers' inputs
- arrive at conclusions on management issues including assumptions of risks (for example, crop failures, plot area needed for trial, help required to set up trials accurately and timing of provision of planting materials)

Other considerations

Plot size. Use plots big enough for farmers to notice differences arising from different treatments. If the researcher plans to sample

Table 12.3

Treatment combinations in an on-farm trial with improved cassava and soybean

(i) Farmer's cassava Improved soybean var. 1	(ii) Farmer's cassava Improved soybean var. 2
(iii) Improved cassava Improved soybean var. 1	(iv) Improved cassava Improved soybean var. 2

Note:

In the treatment combinations, the OFR team does not really have any control (i.e. it is entirely the farmer's field). An immediate solution to this problem is to demarcate a representative area within the farmer's field in which the trial is located and collect data. The crop combinations may be different but in the final analysis what matters is the satisfaction derived by farmers from the systems.

for cassava yield at different ages, plot size is adjusted to accommodate this. The minimum plot size should be 10m x 15m but some farmers may not have as much. The entire trial area should not be more than 20 to 30% of the farmer's field.

Replications. Usually, farmer-managed trials are not replicated within farms. This helps to minimize complications and to reduce total plot area committed to the trial.

Non-treatment variables. Non-treatment variables are routinely recorded. These variables relate to management (for example, weed control, planting patterns and populations, and cropping history of the land as related to inherent soil fertility) and to site-specific features (such as shade, land types, unusual incidence of pests and diseases, and seasonal or annual variations in rainfall). Labor data and farmer participation in the trials is also recorded.

Yield data. Determine yield data accurately because they provide the most important information. For root crops, an OFR team usually determines plot size, number of plants and weight of roots/tubers and shoots at harvest.

Data analysis

Compile data and examine the mean effects of treatments (see Unit 11). Observe farmer-to-farmer variations, and group the project farmers into categories on the basis of yield. Compare yields and interpret trends.

Statistical analysis. Having interpreted trends of yield results, use statistical analysis to establish confidence levels. Indicate the SE or LSD. If interpretation were limited to statistical differences, non-significant LSD or *t* level would indicate that no further discussion of result was necessary. However, in on-farm trials, statistical analysis is a tool to determine confidence level. A non-significant statistical difference may have economic importance.

Economic analysis. Economic analysis of the data is now conducted. It is important to record all inputs so that output can be accurately interpreted. An example of economic analysis for a cassava/soybean system is presented in Table 12.4.

Table 12.4

Costs and returns for cassava/soybean system in the Ohsu area (in Naira)

Item	With TGx536-02D	With Malayan
Average yield (t/ha cassava)+	25.73	27.65
Average yield (t/ha soybean)	2.19	1.35
Net yield (t/ha cassava)	23.16	24.89
Net yield (t/ha soybean)	1.97	1.22
Gross field benefit N220/ton (cassava)	5095.2	5475.8
Gross field benefit soybean (N1500/t)	2955.0	1830.0
Gross grain (cassava + soybean)	8050.2	7305.8
<i>Variable costs</i>		
Land preparation (50MD/ha) at N9/MD ¹	450.0	450.0
Planting (13MD/ha cassava at N9/MD)	117.0	117.0
Planting (15MD/ha soybean at N9/MD)	135.0	135.0
Weeding 60 MD/ha at N9 (2 weedings)	540.0	540.0
Seeds 50kg at N3/kg soybean	150.0	150.0
Cassava cutting 50 bundles at N3	150.0	150.0
Harvesting 70 MD cassava	446.06	479.35
Harvesting 35MD soybean	267.38	164.83
Threshing (32kg/MD)	615.94	379.69
Total variable costs	2871.38	2565.87
Net benefit	5178.82	4739.93
B/C	2.80:1.00	2.85:1.00
Return to labor ² at N9/D per man-day	N18.09	N18.81
Return to labor = (N9/MD)	201%	209%

Note:

1 MD = man-day; D = day

2 Return to labor = net benefit divided by labor costs

The data in Table 12.4 shows that intercropping cassava and soybean is highly profitable, resulting in a realization of about 2 times the value of labor invested or more than 2.5 times the amount of money invested. However, this calculated benefit may not be realized because of the socioeconomic factors, such as volume of gari and soybean markets to absorb increased production, government policy and infrastructural limitations.

Verification trial

The next phase in OFR is the pre-extension verification of the result. This serves as a demonstration as well as a production scale operation through which confidence in the trial package (cassava + soybean) is established. Plots are selected on a few strategically located farms, and plot size may be as large as 0.5-1ha. Analysis is mainly economic and much of the interaction is between the farmers and extension officers. If the trial is successful (that is, meets the farmers' expectations), the package is popularized among target farmers.

A final phase is to study mass adoption of the package at a specific time in the future. Among the issues addressed during this phase are the number of farmers who have adopted the package, the amount of land that has been brought under cultivation using the package and the effect of the package on the farmers' welfare.

Figure 12.6 IITA cassava-based system survey, Ohosu area

Group Interview			
1. Location name: _____		2. Location no. _____	
3. Type of community: _____		Camp/settlement _____	
_____		Traditional village _____	
4. Distance from camp/village to:			
Water supply _____	km	(which) _____	_____
Gari market _____	km		
Tarred road _____	km		
Sec. school _____	km		
Medicare ¹ _____	km	(which maternity) _____	
Agric. people ² _____	km	(which extension) _____	
Notes:			
1. Hospital, clinic, maternity, doctor, nurse, midwife, etc. — indicate which			
2. Agric. officer, extension worker, agric. project, etc. — indicate which			
5. What is the major problem of cassava production in this camp/village?			
6. Cassava variety grown, year of introduction, initial source of cutting, estimated yield			
<i>Variety name</i>	<i>Year introduced</i>	<i>Initial source</i>	<i>Estimated yield</i>

Figure 12.7 IITA cassava-based system survey, Ohosu area

Individual Interview											
1. Location: _____ 2. Name: _____											
3. No. _____ 4. Place of origin: _____											
5. Tribe: _____ 6. Age: _____											
7. Sex: _____ 8. Religion: _____											
9. No. of years spent in school: _____											
10. Secondary occupation: _____											
11. No. of children: _____											
12. No. of children in school: _____											
13. Cassava variety/production calendar											
<i>Field</i>	<i>Variety(ies) planted</i>	<i>Month and year</i>	<i>Month and year</i>								
1											
2											
3											
4											
5											
14. Have you ever given cassava cuttings to anybody outside your camp/village? _____ Yes/No											
15. If yes, where is (are) the person(s)? _____											
16. What crops were in each of your fields in the last planting season, and did you apply fertilizer in each of the fields?											
<i>Field cassava</i>	<i>Area maize</i>	<i>Early maize</i>	<i>Plantain maize</i>	<i>Yam</i>	<i>Green</i>	<i>Grain</i>	<i>Late</i>	<i>Melon</i>	<i>Beans</i>	<i>Veg.*</i>	<i>Fert.</i>
*Name them: _____											

17. Have you ever seen any agric. person? _____
18. If yes, which one? _____
19. How many times has an extension worker visited you in the past 12 months? _____
20. What did you discuss with the extension worker the last time he/she visited you? _____
21. Source of labor (hired/family/lsuzu) for the following farm operations in the last planting season:

<i>Field</i>	<i>Land clearing</i>	<i>Plowing application</i>	<i>Sowing</i>	<i>Weeding</i>	<i>Fertilizer</i>	<i>Staking</i>	<i>Harvesting</i>
1							
2							
3							
4							
5							

22. How much did you spend last year on the following farm inputs?
- Hire labor N
- Planting materials N (materials bought) _____
- Fertilizer N
- Herbicide N
- Insecticide N
- Yam stake N
- Farm tools N
- Tractor hire N (for what purpose) _____
- Other N

23. Which and how many of the members of your household work on your farm and during what periods (months) of the year?

<i>Item</i>	<i>Wives</i>	<i>Grown-up son</i>	<i>Grown-up daughter</i>	<i>Other grown-up relatives</i>	<i>Other children</i>
Number					
Period					

24. Proportion of total production of each crop

<i>Crop</i>	<i>Sold</i>	<i>Consumed</i>	<i>Replanted</i>
Cassava			
Plantain			
Yam			
Maize			
Beans			
Melon			
Other			

25. Type and number of livestock owned

<i>Livestock</i>	<i>Number owned</i>
Chickens	
Sheep/goats	
Pigs	
Cattle	
Other	

26. Tree crops grown (plantation)

Cocoa _____
 Rubber _____
 Oil palm _____
 Kola _____
 Other _____

27. Items of food eaten in the past 24 hours (contd. overleaf)

<i>Meal</i>	<i>Breakfast</i>	<i>Lunch</i>	<i>Dinner</i>	<i>Snack</i>	<i>Other</i>
Cassava					
Starch					
Yam					
Plantain					
Legume					
Fruit maize					
Maize					
Rice vegetable*					

Items of food eaten in the past 24 hours (contd from previous page)

<i>Meal</i>	<i>Breakfast</i>	<i>Lunch</i>	<i>Dinner</i>	<i>Snack</i>	<i>Other</i>
Fish					
Meat					
Melon					
Palm fruit					
Oil*					
Other*					

*Name them: Vegetables _____

Oil _____

Others _____

28. Number of children of your wife/wives, beginning with the youngest wife

<i>Wife</i>	<i>No. of children alive</i>	<i>No. of children dead</i>	<i>No. of children total</i>	<i>No. of children deficient</i>	<i>Symptoms observed</i>
5					
4					
3					
2					
1					

29. Transport vehicle owned _____

30. Ownership of cassava mill Yes: _____ No: _____

31. Ownership of TV Yes: _____ No: _____

 Radio Yes: _____ No: _____

 Spraying equipment Yes: _____ No: _____

 Tractor Yes: _____ No: _____

Figure 12.8 On-station research

Title: Soybean Cassava Intercropping Trial

Objectives: To determine if a reasonable yield of both soybean and cassava can be produced by intercropping the two crops

Experiment: Split plot design
Main plot — intercropping
Monocropping
Sub plot — 11 different varieties of soybean: Replication — 3
Land preparation — slash and burn — no tillage
Date planted cassava and soybean — 17 July 1987
Spacing: Cassava — 1.33m x 0.75m (10,000 plants/ha)
Soybean — 0.75m x 0.05m (266,667 plants/ha)
Fertilization — NONE
Insecticides — NONE
Chemicals for disease control — NONE
Weed control — hand weeding as needed

GLOSSARY

<i>Agronomic trials</i>	Research experiments aimed at investigating field-crop production and/or soil management practices.
<i>Apical dominance</i>	The condition whereby the shoot apex regulates the growth and development of the lateral buds and branches. Auxin, a growth hormone, has been indicated as involved in the process.
<i>Apomixis</i>	Reproduction involving specialized generative tissues but not dependent on fertilization (for example, seed development in the ovary of sexually reproducing plants where the embryo is formed without union of sperm and egg).
<i>Arthropods</i>	Animals with jointed legs, including Crustacea, Myriopoda, Insecta and Arachnoidea.
<i>Axillary bud</i>	A bud formed in the axil of a leaf.
<i>Bacteria</i>	Unicellular micro-organisms belonging to the Kingdom Protista, producing no chlorophyll. They reproduce by binary fission and are related to the fungi. Most are saprophytic, some are autotrophic, and some are parasitic to plants and animals.
<i>Biotics</i>	Pertaining to life.
<i>Breeder seed</i>	Purest form of planting material (for example, cassava stem cuttings) of an improved variety produced by the breeder or his/her agents. The quantity of such material is usually small, and further multiplication at experimental or other sites controlled by a station is necessary to increase the quantity. The resulting material from this multiplication is referred to as foundation seed.
<i>C₃ cycle</i>	Photosynthetic carbon reduction cycle in which the first stable product of photosynthesis is a 3 carbon compound.
<i>C₄ cycle</i>	The photosynthetic carbon reduction cycle in which the first stable product of photosynthesis is a 4 carbon compound.
<i>C:N ratio</i>	The carbon to nitrogen ratio in any chemical or foods, especially proteins.
<i>CO₂ compensation point</i>	CO ₂ concentration at which the amount absorbed is equal to that given off.
<i>Cambium</i>	A layer, usually 1 or 2 cells thick, of persistently meristematic tissue that divides to give rise to secondary tissues, resulting in growth in diameter.
<i>Cercospora</i>	A common parasitic fungus in the subdivision Senteromycotina. It causes leaf spots on different monocotyledonous and dicotyledonous plants. The genus <i>Cercospora</i> is responsible for three leaf spot diseases of cassava.
<i>Chlorotic</i>	The loss of chlorophyll content by a tissue. Usually, tissue turns yellow or pale or even white. The condition is termed chlorosis and may be brought about by disease, genetic factors, lack of light and deficiency in magnesium or iron.

<i>Clone</i>	A group of plants originating from a single individual and reproduced by vegetative means.
<i>Cultivar/variety</i>	A uniform group of cultivated plants obtained by breeding or selection.
<i>Cyanogenic glucosides</i>	Substance called Linamarin found in cassava. Linamarin hydrolyzes in the presence of enzymes (linamarase), giving rise to hydrocyanic acid (HCN).
<i>Die-back</i>	A condition in which the plant shoot dies from the top downwards. Leaves may or may not be shed.
<i>Dormancy</i>	State of suspended biological activity (for example, dormant seeds do not germinate despite provision of normal environmental requirements for the process).
<i>Epiphytotic</i>	Of, relating to, or being a plant disease that tends to recur sporadically and to affect large numbers of susceptible plants.
<i>Etiology</i>	The origin of causes of a disease; the study of causes of a disease.
<i>Fungus</i>	A large group of filamentous and non-filamentous micro-organisms belonging to the Kingdom Protista. They lack photosynthetic pigments (chlorophyll). They are either saprophytic or parasitic. The saprophytic fungi cause food spoilage and wood and debris decay ; parasitic fungi cause diseases of plants and animals.
<i>Genotype</i>	The assemblage of genes in an organism (cf. phenotype).
<i>Genus (pl. genera)</i>	A group of closely related species of plants, animals and micro-organisms.
<i>Halo</i>	A portion of plant tissue devoid of chlorophyll (chlorotic) which surrounds some leaf spots (for example, the chlorotic halo surrounding the bacterial angular leaf spot of cassava caused by <i>Xanthomonas campestris</i> pv <i>cassavae</i>).
<i>Hardwood (of cassava)</i>	The lower matured portion of a cassava stem.
<i>Heterozygous</i>	Having two genes at corresponding loci on homologous chromosomes different for one or more loci.
<i>Host specificity</i>	Usually found in pathogens. Host-specific pathogens cannot attack any plants other than their host (for example, <i>Xanthomonas campestris</i> pv <i>manihotis</i> has not been shown to attack any plant apart from cassava, hence it is host-specific).
<i>Hydrocyanic acid (HCN)</i>	A very toxic compound found in many plants, including cassava. In cassava, HCN is concentrated mainly in the peel of the tuber and in the leaves.
<i>Interspecific crosses</i>	Interbreeding or hybridization involving representatives of different species.
<i>In vitro</i>	Literally means 'in glass'. It is now applied to any process carried out in sterile cultures.
<i>Laticifers</i>	Vessels containing latex found in the cassava tuber flesh.

<i>Leaf picrate method</i>	A rapid means of testing the amount of HCN released by discs cut from cassava leaves where the quantity of HCN corresponds to the intensity of color (dark red for high HCN) developed when a filter paper soaked in sodium picrate is suspended in a vial containing the leaf disc and a few drops of toluene.
<i>Lesion</i>	A wound; a well-marked but limited diseased area.
<i>Meristem culture</i>	Apical meristem culture; cultivation of the apical dome tissue distal to the youngest leaf primordia in prepared nutrient media.
<i>Micropyle</i>	A minute opening in the integument of an ovule of a seed plant through which the pollen tube penetrates to the embryo sac.
<i>Morphology</i>	The study of form and its development; the form and structure of an organism or any of its parts.
<i>Mottling</i>	The presence of a mixture of many colors on the leaf surface caused usually by viruses and occasionally by other factors.
<i>Mutation</i>	A relatively permanent change in hereditary material involving either a physical change in chromosome relations or a biochemical change in the make-up of the genes; the process of producing a mutation; an individual or strain resulting from mutation.
<i>Mycelium (pl: mycelia)</i>	A collection of fungal filaments (hyphae).
<i>Necrosis</i>	The death of part of or the whole of a plant.
<i>Outcross</i>	A progeny resulting from interbreeding involving relatively unrelated individuals.
<i>Parthenogenetic</i>	Plants developed from seed or ovum without fertilization by pollen.
<i>Perennial</i>	A plant that lives an indefinite number of years (perennis: lasting for the whole year)
<i>Plantlet</i>	A small rooted shoot or germinated embryo.
<i>Polyploid</i>	Having or being a chromosome number that is a multiple greater than 2 of the genetic number.
<i>Propagation</i>	Methods of raising or establishing crop plants.
<i>Pubescence</i>	Quality or state of being covered with soft short hairs (pubescent: covered with soft hair, as is the case with young leaves and shoots of some cassava varieties.
<i>Recombination</i>	The formation through the processes of crossing-over and independent assortment of new combinations of genes in progeny that did not occur in the parents.
<i>Recurrent selection</i>	A plant-breeding practice whereby progenies from intermating of a group of parents selected for their breeding values are tested for good performance. Selected plants are constituted as parents of the next generation through intermating.

<i>Replication</i>	Systematic or random repetition of experimental units like agricultural test rows or plots to reduce error.
<i>Rogueing</i>	The removal of unwanted varieties or plants of undesired characteristics to prevent them from mixing with or contaminating the desired variety.
<i>Secondary thickening</i>	Formation of additional, secondary vascular tissue by activity of cambium, with accompanying increase in diameter of stems and roots of plants; providing additional conducting and supporting tissue for the growing plant.
<i>Species</i>	A group of interbreeding individuals not interbreeding with another such group; a systematic unit which includes geographic races and varieties and is included in a genus.
<i>Stem puncture method</i>	Procedure whereby cassava stems are punctured with a needle for inoculation purposes. Usually, plant pathogens are inoculated into such punctures.
<i>Subculture</i>	Subdivision of a culture for transfer to fresh medium.
<i>Supra-optimal temperature</i>	The temperature most ideal for a biological process such as disease development or the growth of a fungus or bacterium.
<i>Systemic</i>	Generally distributed throughout the system (that is, the plant system).
<i>Tetranychids</i>	Having to do with mites.
<i>Tuber</i>	A thickened, fleshy underground root or stem.
<i>Variation</i>	The divergence in the structural or physiological characters of an organism or biotype from those typical or usual to its group; the extent or range of such divergence.
<i>Vascular necrosis</i>	Death of the plant vascular system.
<i>Vector</i>	A carrier of pathogenic organisms; any agent transferring a parasite to a host.
<i>Viral</i>	Consisting of or due to a virus.
<i>Virus</i>	One of the nucleoprotein-like entities able to pass through bacteria-retaining filters, having many characteristics of living organisms and recognized by its toxic or pathogenic effects in plants and animals, including man.
<i>Volunteer seedlings</i>	Seedlings resulting from seeds other than those intentionally sown (for example, through germination of seeds from an earlier planting).
<i>Xanthomonas</i>	One of the five bacteria genera pathogenic to plants. The genus is usually characterized by rod shape with a single polar flagellum and yellow colonies (with a few exceptions), and causes angular necrotic leaf spots, gum exudation, wilt, and die-back of young shoots (for example, <i>Xanthomonas campestris</i> or <i>manihotis</i>).

RECOMMENDED READING

Production constraints

Hahn, S.K., E.R. Terry, K. Leuschner, I.O. Akobundu, C. Okali, and R. Lal. 1979. 'Cassava improvement in Africa' *Field Crops Research* 2 : 193-226

Onwueme, I.C. 1978. *The Tropical Tuber Crops* John Wiley, Chichester

Storey, H.H., and R.F.W. Nichols. 1938. 'Studies on the mosaic diseases of cassava' *Annals of Applied Biology* 25 : 790-806

Morphology and physiology

Cock, J.H. 1973. 'Some physiological aspects of yield in cassava (*Manihot esculenta* Crantz)' in *Proceedings of 3rd International Symposium on Tropical Root Crops*, Ibadan, Nigeria

Cock, J.H., and J.A. Reyes (eds). 1985. *Cassava Research, Production and Utilization* UNDP/CIAT

Enyi, B.A.C. 1972. 'Growth rates of three cassava varieties under varying population densities' *Journal of Agricultural Science, U.K.* 81 : 15-28

Hunt, L.A, D.W. Wholey, and J.H. Cock. 1977. *Growth Physiology of Cassava* *Field Crops Abstracts* (vol 30, no 2)

Onwueme, I.C. 1978. *The Tropical Tuber Crops* John Wiley, Chichester

Breeding

Hahn, S.K. 1980. 'Research priority, techniques and accomplishments in cassava breeding' *Roots Crops in Eastern Africa* *Proceedings of a workshop held in Kigali, Rwanda* IDRC-177e 19-22 IDRC, Ottawa

Hahn, S.K., A.K. Howland, and E.R. Terry. 1980. 'Correlated resistance of cassava to mosaic and bacterial blight diseases' *Euphytica* 29 : 305-311

Jennings, D.L., and C.H. Hershey. 1985. 'Cassava breeding: A decade of progress from international programmes' in Russell, G.E. (ed) *Progress in Plant Breeding - 1* Butterworth

Jones, W.O. 1959. *Manioc in Africa* Stanford University Press, Stanford

Kawano, K. 1980. 'Cassava' in Fehr, W.R. and Hadley, H.H. (eds) *Hybridization of Crop Plants* American Society of Agronomy, Madison, Wisconsin, USA

Nichols, R.F.W. 1947. 'Breeding cassava for virus resistance' *East African Agricultural and Forestry Journal* 12 : 184-194

Multiplication and distribution

Cock, J.H., and J.A. Reyes (eds). 1985. *Cassava: Research, Production and Utilization* UNDP/CIAT

Dahniya, M.T., and S.N. Kallon. 1984. 'Rapid multiplication of cassava by direct planting' Proceedings of 2nd Triennial Symposium of the International Society for Tropical Root Crops — Africa Branch, Douala, Cameroon, 14-19 August 1983

Heys, G.E. 'Large-scale multiplication of cassava at IITA, Ibadan' in (ed) H.C. Ezumah. *Cassava Production and Extension in Central Africa: Proceedings of a Workshop held in Mbaza-Ngungu, Zaïre, 19-22 May 1980* Proceedings Series No. 4, IITA

IITA. 1988. 'New alternative technique for sprouting cassava without soil for rapid multiplication' IITA Annual Report and Research Highlights 1987/88 126-127

Lozano, J.C., and D.W. Wholey. 1974. 'The production of bacteria-free planting stock of cassava.' *World Crops Journal* 26 : 114-117

Lozano, J.C., J. Toro, A. Castro, and A.C. Bellotti. 1977. *Production of Cassava Planting Material* CIAT Series GE-17

Terry, E.R. 'The production of pathogen-free cassava planting material for distribution' in (ed) H.C. Ezumah *Cassava Production and Extension in Central Africa: Proceedings of Workshop held in Mbaza-Ngungu, Zaïre, 19-22 May 1980* Proceedings Series No. 4, IITA

Tissue culture

Bhojwani, S.S., and N.K. Razdan. 1983. *Plant Tissue Culture: Theory and Practice* Elsevier, Amsterdam

Evans, D.A., W.R. Sharp, P.V. Ammirato, and Y. Yamada. 1983. *Handbook of Plant Cell Culture* Macmillan, New York/London

Fogh, J. 1973. *Contamination in Tissue Culture* Academic Press, New York

George, E.F., and P.D. Sherrington. 1984. *Plant Propagation by Tissue Culture* Exegetics Ltd, UK

Ingram, D.S., and J.P. Helgeson. 1980. *Tissue Culture Methods for Plant Pathologists* Blackwell, Oxford

Agronomy

Cock, J.H., and J.A. Reyes (eds). 1985. *Cassava: Research, Production and Utilization* UNDP/CIAT

Leihner, D. 1983. *Management and Evaluation of Intercropping Systems with Cassava* CIAT

Okigbo, B.N. 1971. 'Effect of planting dates on the yield and general performance of cassava (*Manihot utilissima* Pohl)' *Nigerian Agricultural Journal* 8 : 115-122

Onwueme, I.C. 1978. *The Tropical Tuber Crops* John Wiley, Chichester

Weber, E.J., J.C. Toro, and M. Graham (eds). 'Proceedings of a workshop held in Salvador, Bahia, Brazil, 18-21 March 1980'

Crop protection

- Hahn, S.K., J.C.G. Isoba, and T. Ikotun. 1989. 'Resistance breeding in root and tuber crops at the International Institute of Tropical Agriculture (IITA), Ibadan, Nigeria' *Crop Protection* 8: 147-168
- Leuschner, K., E.R.Terry, and T.A. Akinlosotu. 1982. *Field Guide for Identification and Control of Cassava Pests and Diseases in Nigeria* Manual Series No. 3. IITA
- Lozano, J.C., and R.H. Booth. 1974. 'Diseases of Cassava (*Manihot esculenta* Crantz)' *Pest Articles and News Summary* 20 : 30-54
- Lozano, J.C., A.C. Bellotti, J.A. Reyes, R. Howller, D. Leihner, and J. Doll. 1981. *Field Problems in Cassava* CIAT
- Neuenschwander, P., H.R. Herren, R. Hennessey, W.N.O. Hammond, K.M. Lema, D. Sullivan, F. Schulthess, and E. Madojemu. 1985. '*Epidinocarsis lopezi* in Africa' IITA Annual Report 1984
- Terry, E., and J.O. Oyekan. 1978. 'Cassava diseases in Africa reviewed' *Pest Articles and News Summary* 19 : 116-118
- Théberge, R.L. (ed). 1985. *Common African Pests and Diseases of Cassava, Yam, Sweet Potato and Cocoyam* IITA
- Yaninek, J.S., and H.R. Herren. 1985. 'Natural enemies of CGM' IITA Annual Report 1984

Storage, processing and utilization

- Almazan, A.M. 1988. 'A guide to the picrate test for cyanide in cassava leaf/Détermination de l'acide cyanhyrique des feuilles de manioc par la méthode au picrate' (Bilingual brochure) IITA, Ibadan
- Cock, J. H. 1985. *Cassava, New Potential for a Neglected Crop* IADS Development-Oriented Literature Series Westview Press, Boulder
- Hahn, N.D. (ed). 1989. *In praise of cassava* Proceedings of the Interregional Expert Group Meeting on the Exchange of Technologies for Cassava Processing Equipment and Food Products, Ibadan, Nigeria 13-19 April 1988 UNICEF/IITA
- Kwatia, J.T. 1986. *Rural Cassava Processing and Utilization Centers* UNICEF/IITA
- Mahungu, N.M., Y. Yamaguchi, A.M. Almazan, and S.K. Hahn. 1987. 'Reduction of cyanide during processing of cassava into some traditional African foods' *Journal of Food and Agriculture* 1: 11-15
- Onabolu, A. 1988. *Sweet Cassava: Food for All Seasons* UNICEF/IITA
- Rao, Poonam V., and S.K.Hahn. 1984. 'An automated enzymatic assay for determining the cyanide content of cassava (*Manihot esculenta* Crantz) and cassava products' *Journal of the Science of Food and Agriculture* 35: 426-436
- Rosling, H. 1987. *Cassava toxicity and food security: A review of health effects of cyanide exposure from cassava and of ways to prevent these effects* A report for UNICEF African Household Food Security Program Tryck kontakt, Uppsala, Sweden

Data collection and organization

Cochran, W.G., and G.M. Cox. 1957. *Experimental Design* John Wiley, Chichester

Fisher, R.A., and F. Yates. 1948. *Statistical tables for biological, agricultural and medical research* Oliver and Boyd, Edinburgh

Mead, R., and R.N. Curnow. 1983. *Statistical Methods in Agriculture and Experimental Biology* Chapman and Hall, London

On-farm research

Byerlee, D., M.P. Collinson, et al. 1980. *Planning Technologies Appropriate to Farmers: Concepts and Procedures* CIMMYT

Hildebrand, P.E. 1981. 'Combining disciplines in rapid appraisal: The sondeo approach' *Agricultural Administration* 8 : 423-432

■ Hildebrand, P.E. 1984. 'Modified stability analysis of farmer-managed on-farm trials' *Agronomy Journal* 76 : 271-274

Mutsaers, H.J.W., N.M. Fischer, W.O. Vogel, and M.C. Palada. 1986. *A Field Guide for On-Farm Research* IITA

Okigbo, B.N., and D.J. Greenland. 1976. 'Intercropping systems in tropical Africa' in (eds) P.M. Stelly, L.C. Eisele Kral, and H.J. Nauseef. *Multiple Cropping* American Society of Agronomy, Madison, Wisconsin

Zandstra, H.G., E.C. Price, J.A. Litsinger, J.A., and R.A. Morris. 1981. *A Methodology for On-farm Cropping Systems Research* IRRI

About IITA The goal of the International Institute of Tropical Agriculture (IITA) is to increase the productivity of key food crops and to develop sustainable agricultural systems that can replace bush fallow, or slash and burn, cultivation in the humid and subhumid tropics of Africa. Crop improvement programs focus primarily on cassava, maize and cowpeas. Yams, soybean and plantain are also major research concerns. Research findings are shared through international cooperation programs which include training, information and germplasm exchange activities.

IITA was founded in 1967. The Federal Government of Nigeria provided a land grant of 1,000 hectares at Ibadan, for a headquarters and experimental farm site, and the Rockefeller and Ford foundations provided financial support. IITA is governed by an international Board of Trustees. The staff includes nearly 200 scientists and professional staff from about 40 countries, who work at the Ibadan campus and on substations and outreach programs in many countries of sub-Saharan Africa.

IITA is one of 13 nonprofit, international agricultural research centers and programs supported by the Consultative Group for International Agricultural Research (CGIAR). Established in 1971, CGIAR is an association of about 50 countries, international and regional organizations and private foundations. The purpose of the research effort is to improve the quantity and quality of food production in developing countries. The World Bank, the Food and Agriculture Organization of the United Nations (FAO) and the United Nations Development Programme (UNDP) are cosponsors of this effort.

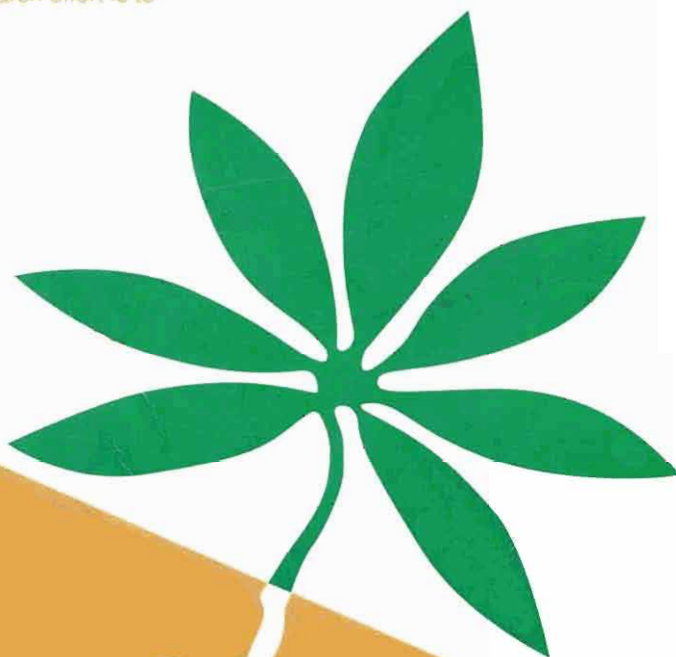

**International
Institute of
Tropical
Agriculture**

**PMB 5320
Oyo Road
Ibadan
Nigeria**

